



20210 ACPA QCAST

Plant Certification Manual



ACPA QCAST PLANT CERTIFICATION

The American Concrete Pipe Association (www.concretepipe.org) offers QCast Plant Certification (qcast.org) as a voluntary program to continue the advancement of quality in the precast concrete pipe and products industry. The ACPA and its Board of Directors are committed to providing excellence in quality management and therefore all activities related to the QCast plant certification program shall be conducted in an open and impartial manner.

The purpose of this manual is to establish the ACPA's Certification Program requirements. This manual shall form a basis by which ACPA's third party audit agency will audit participating Pipe, Manhole, Box Culvert, Three-Sided Structure, Precast and Gasket Manufacturers' plants. The manual includes:

- Requirements for calibration and certification of production, testing, and inspection equipment and instrumentation,
- Requirements for ongoing plant (internal) inspection and test documentation,
- Requirements for product tests and documentation,
- Requirements for raw material certification documentation,
- Requirements for third party audit verification,
- Requirements for product design documentation,
- Requirements for product storage, handling, and repair.

Plant Management is ultimately responsible for the quality of the product made in their plant. They shall ensure that the supervisory and production personnel immediately responsible for product quality are properly trained.

MANUAL ORGANIZATION

This Manual is organized into “common” and “product specific” sections for the easy retrieval of applicable requirements. Section I details the requirements that are common to all product categories. Sections II through V contain product-specific certification requirements. All

Sections of this Manual reference Appendix A. Appendix B contains Audit Expectations to be performed, checked or witnessed during the annual audit.

Manual Sections

- I Common Program Requirements
- II Pipe Requirements
- III Manhole Requirements
- IV Engineered Precast Products
- V Box Culvert and Three-sided Structures Requirements
- VI Gasket Manufacturing Requirements
- VII Appendix A: Procedures & Forms
- VIII Appendix B: Audit Expectations

Plants may elect any single or multiple product specific certification or full Plant Certification to meet local or state requirements. Current certifications offered include: Storm Sewer and Culvert Pipe, Sanitary Sewer pipe, Manholes, Sanitary Sewer Manholes, Box Culvert and Three-Sided Structure, Engineered Precast Products, Gaskets, and full plant Certification. If full Plant Certification is chosen, then all products covered by this Manual will be audited to the requirements of this Manual. For each product specific certification, the QCast requirements shall apply for all products made under that certification, regardless of the project. Flared end sections can be certified under pipe, manhole, or precast certification, depending on the certification selected and will be audited based on the precast requirements. No other products are certified based on this manual. The evaluation, review, decision, and re-certification are confined to the matters specifically related to the scope of this manual

In order to receive certification, plants shall meet the requirements of the ACPA's Plant Certification Manual and demonstrate compliance to a third party audit. The independent third party auditor shall conduct the audits professionally and impartially. The process begins when the plant submits an application and an application fee to the ACPA. The ACPA's third party certification auditing firm then schedules the audit. Upon receiving a passing score, the plant is sent a certificate by the ACPA.

For more information regarding the QCast Program, contact the ACPA offices at info@concretepipe.org.

TABLE OF CONTENTS

| | |
|---|----|
| Table of Contents | iv |
| CERTIFICATION BYLAWS | 1 |
| SECTION I | 10 |
| COMMON PROGRAM REQUIREMENTS | 10 |
| 1. Quality Documentation, Specifications and Information | 10 |
| 1.1. Company/Plant Quality Control Manual | 10 |
| 1.2. Current ACPA QCast Plant Certification Manual | 10 |
| 1.3. Current Applicable ASTM Standards | 10 |
| 1.4. Documentation for Special Project Specifications | 11 |
| 1.5. Management Structure and Quality Control Coordinator | 11 |
| 1.6. Quality Authority / Hold Production Policy | 11 |
| 1.7. QC Meetings | 12 |
| 1.8. QC Personnel Training | 12 |
| 1.9. Quality Audits | 12 |
| 2. Materials | 12 |
| 3. Calibration | 13 |
| 4. Mix Designs | 14 |
| 4.1. Water | 14 |
| 4.2. Water/Cementitious Material Confirmation | 14 |
| 4.3. Concrete Batch Reports | 14 |
| 4.4. Self-Consolidating Concrete (SCC) | 15 |
| 4.5. Flowable Concrete | 15 |
| 5. Joints | 15 |
| 5.1. Joint Design Drawings | 15 |
| 5.2. Joint Design Calculations | 15 |
| 5.3. Spigot Go/No-Go Gauge (or optional measuring system) | 15 |
| 5.4. Gasket Quality | 15 |
| 6. Equipment | 16 |
| 7. Reinforcing | 16 |
| 8. Pre-Pour Inspection | 16 |
| 8.1. Welded Splice Pull Test | 16 |
| 9. Concrete Testing | 16 |

| | | |
|-------------------------|---|----|
| 9.1. | Slump/Slump Flow Test of Wet Cast Concrete | 17 |
| 9.2. | T ₂₀ - Relative Measure of Flow Rate and Viscosity SCC (ASTM C 1611) | 17 |
| 9.3. | VSI Index Flowable & SCC (ASTM C 1611)..... | 17 |
| 9.4. | Air Content Tests..... | 17 |
| 9.5. | Unit Weight Tests..... | 18 |
| 9.6. | Temperature Tests (ASTM C 1064)..... | 18 |
| 9.7. | Concrete Absorption Test Results | 19 |
| 9.8. | Out-Sourced Concrete | 19 |
| 9.9. | Concrete Compression Tests (ASTM C 39) | 19 |
| 10. | Curing..... | 20 |
| 11. | Post-Pour Inspection | 20 |
| 12. | Product Marking | 20 |
| 13. | Product Testing..... | 20 |
| 14. | Storage, Handling, Shipping and Final Inspection..... | 20 |
| 14.1. | Handling and Storage | 21 |
| 14.2. | Shipping Policy..... | 21 |
| 14.3. | Final Inspection..... | 21 |
| SECTION II | | 22 |
| PIPE REQUIREMENTS | | 22 |
| 1. | Quality Documentation | 22 |
| 2. | Materials..... | 22 |
| 3. | Calibration | 22 |
| 4. | Mix Design | 22 |
| 5. | Joints..... | 22 |
| 5.1. | Joint Design Drawings..... | 22 |
| 5.2. | Joint Design Calculations - Sanitary Sewer Pipe | 22 |
| 5.3. | Spigot Go/No-Go Gauge (or optional measuring system) - Sanitary Sewer Pipe..... | 23 |
| 5.4. | Gasket Quality | 23 |
| 6. | Equipment | 23 |
| 6.1. | Forms | 23 |
| 6.2. | Joint Forming Equipment Inspection..... | 23 |
| 7. | Reinforcing..... | 24 |
| 7.1. | In-Plant Drawn Wire | 25 |
| 8. | Pre-Pour Inspection..... | 25 |

| | | |
|----------------------------|---|----|
| 8.1. | Reinforcing Inspection | 25 |
| 8.2. | Pre-Pour Visual Inspection..... | 25 |
| 8.3. | Pre-Pour Dimensional Inspection | 26 |
| 9. | Concrete Testing..... | 26 |
| 10. | Curing..... | 26 |
| 11. | Post-Pour Inspection | 26 |
| 11.1. | Finishing and Repairs | 26 |
| 11.2. | Pipe Barrel Visual Inspection | 26 |
| 11.3. | Dimensional Test Reports on Pipe Barrels | 26 |
| 11.4. | Pipe Joint Visual Inspection | 27 |
| 11.5. | Dimensional Test Reports on Pipe Spigots - Sanitary Sewer | 27 |
| 12. | Product Marking | 27 |
| 13. | Product Testing..... | 27 |
| 13.1. | Water Tightness of Pipe – Sanitary Sewer | 27 |
| 13.2. | Three-Edge-Bearing Testing of Pipe | 27 |
| 13.3. | Off-Center Joint Test - Sanitary Sewer | 29 |
| 13.4. | Differential Joint Shear Test - Sanitary Sewer | 29 |
| 13.5. | Storm Sewer and Culvert Joint Test - Storm and Culvert..... | 29 |
| 14. | Storage, Handling, Shipping and Final Inspection | 30 |
| SECTION III | | 31 |
| MANHOLE REQUIREMENTS | | 31 |
| 1. | Quality Documentation, Specifications and Information | 31 |
| 2. | Materials..... | 31 |
| 3. | Calibration | 31 |
| 4. | Mix Design | 31 |
| 5. | Joints..... | 31 |
| 5.1. | Joint Design Drawings..... | 31 |
| 5.2. | Joint Design Calculations - Sanitary Manholes | 31 |
| 5.3. | Spigot Go/No-Go Gauge (or optional measuring system) - Sanitary Manholes..... | 31 |
| 5.4. | Gasket Quality | 32 |
| 6. | Equipment | 32 |
| 6.1. | Forms | 32 |
| 6.2. | Joint Forming Equipment Inspection..... | 32 |
| 7. | Reinforcing..... | 33 |

| | | |
|-------|---|----|
| 8. | Pre-Pour Inspection..... | 34 |
| 8.1. | Reinforcing Inspection..... | 34 |
| 8.2. | Pre-Pour Visual Inspection..... | 34 |
| 8.3. | Pre-Pour Dimensional Inspection..... | 34 |
| 9. | Concrete Testing..... | 34 |
| 10. | Curing..... | 34 |
| 11. | Post-Pour Inspection..... | 34 |
| 11.1. | Finishing and Repairs..... | 35 |
| 11.2. | Manhole Visual Inspection..... | 35 |
| 11.3. | Dimensional Test Reports on Manholes..... | 35 |
| 11.4. | Manhole Joint Visual Inspection..... | 35 |
| 11.5. | Dimensional Test Reports on Manhole Spigots - Sanitary Sewer..... | 35 |
| 12. | Product Marking..... | 35 |
| 13. | Product Testing..... | 36 |
| 13.1. | Water Tightness of Sanitary Sewer Manholes..... | 36 |
| 13.2. | Manhole Step Testing..... | 36 |
| 14. | Storage, Handling, Shipping and Final Inspection..... | 36 |
| | SECTION IV..... | 37 |
| | ENGINEERED PRECAST PRODUCTS..... | 37 |
| 1. | Quality Documentation, Specifications and Information..... | 37 |
| 1.1. | Production Drawings..... | 37 |
| 2. | Materials..... | 37 |
| 3. | Calibration..... | 37 |
| 4. | Mix Designs..... | 37 |
| 5. | Joints..... | 37 |
| 6. | Equipment..... | 37 |
| 7. | Reinforcing..... | 38 |
| 8. | Pre-Pour Inspection..... | 38 |
| 8.1. | Pre-Pour Reinforcing Inspection..... | 38 |
| 8.2. | Pre-Pour Visual Inspection..... | 38 |
| 8.3. | Pre-Pour Dimensional Inspections..... | 39 |
| 9. | Concrete Testing..... | 39 |
| 10. | Curing..... | 39 |
| 11. | Post-Pour Inspection..... | 39 |

| | | |
|-----------------------------------|---|----|
| 11.1. | Finishing and Repairs | 39 |
| 11.2. | Visual Inspection | 39 |
| 11.3. | Dimensional Test Reports | 39 |
| 11.4. | Joint Visual Inspection | 40 |
| 12. | Product Marking | 40 |
| 13. | Product Testing..... | 40 |
| 14. | Storage, Handling, Shipping and Final Inspection | 40 |
| SECTION V | | 41 |
| BOX CULVERT AND THREE-SIDED | | 41 |
| STRUCTURE REQUIREMENTS..... | | 41 |
| 1. | Quality Documentation, Specifications and Information | 41 |
| 2. | Materials..... | 41 |
| 3. | Calibration | 41 |
| 4. | Mix Designs..... | 41 |
| 5. | Joints..... | 41 |
| 5.1. | Joint Design Drawings..... | 41 |
| 5.2. | Joint Design Calculations - Gasketed Box Culvert..... | 41 |
| 5.3. | Spigot Go/No-Go Gauge (or optional measuring system) - Gasketed Box Culvert | 41 |
| 5.4. | Gasket Quality | 42 |
| 6. | Equipment | 42 |
| 6.1. | Joint forming Equipment Gasketed Box Culvert..... | 42 |
| 7. | Reinforcing..... | 42 |
| 7.1. | Design | 42 |
| 8. | Pre-Pour Inspection..... | 42 |
| 8.1. | Reinforcing Inspection | 42 |
| 8.2. | Pre-Pour Visual Inspection | 43 |
| 8.3. | Pre-Pour Form Dimensional Inspection..... | 43 |
| 9. | Concrete Testing..... | 44 |
| 10. | Curing..... | 44 |
| 11. | Post-Pour Inspection..... | 44 |
| 11.1. | Finishing and Repairs | 44 |
| 11.2. | Visual Appearance | 44 |
| 11.3. | Dimensional Inspection | 44 |
| 11.4. | Dimensional Test Reports on Box Culvert Gasket Sealing Surfaces..... | 45 |

| | | |
|-------|---|----|
| 12. | Product Marking | 45 |
| 13. | Product Testing..... | 45 |
| 14. | Storage, Handling, Shipping and Final Inspection | 45 |
| | SECTION VI | 46 |
| | GASKET REQUIREMENTS | 46 |
| 1. | Quality Documentation, Specifications and Information | 46 |
| 1.8. | QC Personnel Training | 46 |
| 2. | Materials..... | 46 |
| 2.1. | Material – Gasket Cord (purchased)..... | 46 |
| 2.2. | Material – Rubber Compound | 46 |
| 2.3. | Material – Joint Lubricant..... | 46 |
| 3. | Calibration | 47 |
| 4. | Mix Design - Not applicable to gaskets..... | 47 |
| 5. | Joints..... | 47 |
| 5.4. | Gasket Quality | 47 |
| 6. | Equipment | 48 |
| 7. | Reinforcing - Not applicable to gaskets. | 48 |
| 8. | Pre-Pour Inspection | 48 |
| 8.1. | Gasket Production QC Testing Frequency | 48 |
| 8.2. | Production Control and In-Process Testing | 49 |
| 8.3. | QC/Production Inspection | 50 |
| 9. | Concrete Testing - Not applicable to gaskets. | 51 |
| 10. | Curing - Not applicable to gaskets..... | 51 |
| 11. | Post-Pour Inspection | 51 |
| 11.1. | Finishing and Repairs..... | 51 |
| 12. | Product Marking | 51 |
| 13. | Product Testing – not applicable to gaskets..... | 51 |
| 14. | Storage, Handling, Shipping and Final Inspection | 51 |
| 14.1. | Handling and Storage | 52 |
| 14.2. | Shipping Policy..... | 52 |
| 14.3. | Final Inspection..... | 52 |
| | APPENDIX A: | 53 |
| a. | Gasket manufacturer producing gaskets from gasket cord | 75 |
| b. | Gasket manufacturer producing gaskets from rubber compound..... | 75 |

| | |
|--|-----|
| a. Gasket manufacturer producing gaskets from gasket cord | 75 |
| b. Gasket manufacturer producing gaskets from rubber compound..... | 75 |
| a. Gasket manufacturer producing gaskets from gasket cord | 76 |
| Appendix B..... | 124 |
| Audit Expectations..... | 124 |
| 1. Quality Documentation, Specifications and Information | 125 |
| 2. Materials..... | 125 |
| 3. Calibration | 125 |
| 4. Mix Designs..... | 125 |
| 5. Joints | 125 |
| 6. Equipment | 126 |
| 7. Reinforcing..... | 126 |
| 8. Pre-Pour Inspection | 126 |
| 9. Concrete Testing..... | 127 |
| 10. Curing..... | 127 |
| 11. Post-Pour Inspection..... | 127 |
| 12. Product Marking | 128 |
| 13. Product Testing - Pipe and Manhole Only..... | 128 |
| 14. Storage, Handling, Shipping and Final Inspection..... | 129 |
| APPENDIX C: | 140 |
| 1. SCOPE | 141 |
| 2. REFERENCED DOCUMENTS..... | 142 |
| 3. AUDIT | 143 |
| 4. CLOSURE | 148 |

CERTIFICATION BY-LAWS

Introduction

The procedures are implemented to ensure that ACPA's QCast Certification Program is administered properly and consistently.

The ACPA's QCast Certification Program consists of three elements:

1. **Procedures:** Each participating manufacturer of concrete storm sewer and culvert pipe, manholes, sanitary sewer pipe, precast products, box culverts and three-sided precast structures, and Gaskets (herein after referred to as the manufacturer) shall maintain sufficient procedures and documentation to assure that these types of products are consistently manufactured, inspected, and tested in accordance with guidelines of this manual.
2. **Initial and Recertification Audits:** The plant shall be audited in accordance with the ACPA Plant Certification Manual and the elements specified therein. Audits shall be performed by a recognized professional audit firm with knowledge of the products covered in the manual. A resume of each auditor shall be retained in the auditing firm's files and provided to participating manufacturers upon request. The auditors shall be trained in the requirements of this program prior to performing an audit. Should a participating manufacturer have doubts as to the qualifications or competence of an auditor, the participating manufacturer may petition the ACPA for relief, following appeal procedures outlined in this document.
3. **Enforcement:** Achievement and maintenance of the ACPA certificate of compliance is contingent on full compliance with these procedures. No participating manufacturer may use or reference an expired certificate. Legal action may be taken against manufacturers for violating this precept.

Scope of Application

The ACPA Audit and Certification Program applies to participating manufacturers of concrete pipe, manholes, engineered precast products, box culverts and three-sided structures, and Gaskets. The requirements of this program are designed to demonstrate, that at the time of the audit, the certified manufacturing plant was manufacturing in compliance with ACPA guidelines, and that production operations and procedures are in place to facilitate continued compliance with the guidelines of this manual.

Initial Certification of Manufacturers

- Manufacturers, who voluntarily desire to obtain certification that their manufacturing plant is producing precast concrete products and/or Gaskets in compliance with this program,

shall submit an application to the ACPA. In the application, the manufacturer shall specify the plant to be audited and the certification sought. If more than one plant is to be audited, a separate application shall be submitted for each plant. Applications are available on the ACPA website at www.concretepipe.org. The manufacturer shall submit a copy of their Plant Quality Control Manual with the initial application. The manual should address each aspect of the certification being audited for. Based on the review, revisions to the plant's manual and procedures may be necessary prior to scheduling the initial audit. It is the manufacturer's responsibility to ensure that adequate product, required documentation, and tests are available for the third-party audit agency to perform a complete audit.

- Within 20 working days of receipt of the certification application, the ACPA will arrange the auditor assignment and audit schedule with the applicant manufacturer. Applicants shall be notified of the audit date a minimum of 2 weeks prior to the audit. The applicant shall have all elements available for inspection.
- Upon receipt of a satisfactory audit, the ACPA shall award the applicant a certificate of compliance, valid until the following
 - January 1st (hereinafter referred to as 1st Quarter) if initially audited between January 1- March 31,
 - April 1st (hereinafter referred to as 2nd Quarter) if initially audited between April 1- June 30,
 - July 1st (hereinafter referred to as 3rd Quarter) if initially audited between July 1- September 31,
 - October 1st (hereinafter referred to as 4th Quarter) if initially audited between October 1-December 31

Compliance certification shall be awarded on the basis of:

1. Acceptable compliance with product requirements specified in this plant certification manual, and
 2. Maintenance of sufficient documentation to demonstrate continued compliance with this plant certification manual.
- A manufacturer's plant must pass the audit under two guidelines: 1) by receiving an overall audit score of 80 or more and, 2) by receiving a score of 75 percent or more on each of the identified critical audit elements.
 - Plants that fail a Combined Storm Sewer and Culvert, and Sanitary Sewer Pipe Certification may still gain Storm Sewer and Culvert Pipe Certification if the plant passes

all Storm Sewer and Culvert Pipe Certification achieves an overall score greater than 80, and a score greater than 75 on critical items.

- The successful manufacturer's plant shall also be awarded a certificate of compliance. The certificate shall identify the plant as being certified and may be displayed for customers and employees. An electronic logo shall also be available to the plant to create a QCast stencil. The stencil may be used to mark product as being produced by an ACPA certified plant.

Recertification of Manufacturers' Plant(s)

- In order to maintain certification for the subsequent year, a plant must re-apply and make payment by their quarterly anniversary date as shown in the bylaws of the QCast Manual. Upon receipt of the application and payment, the ACPA acknowledges the plants intent to continue in the program, and the plant is placed in the auditing queue and issued a certificate. The certificate is valid until the following anniversary date, unless the annual audit is not passed. If the audit is not passed, the plant is removed from the certified list on the date that the official report was issued from ACPA, until they complete a successful audit.
- The auditor shall conduct an unannounced audit within 12 months of the plant's anniversary date.
 1. If a manufacturer adds Box Culvert, Sanitary Sewer Pipe or Sanitary Manhole Certification to an existing Storm Sewer Pipe, Precast or Manhole Certification an announced audit will occur.
 2. A manufacturer's plant may fail the audit in two ways: 1) by receiving an overall audit score of less than 80, or 2) by receiving a score of less than 75 percent on any one of the identified critical audit elements.
 3. Plants having Box Culvert certification must demonstrate box production at least every other audit year to remain Box certified. If box production is not observed during an audit, sections related to observation of production activities will be graded the same as the most recent QCast audit grade when procedures were demonstrated. Further grade deductions may be made based on poor recordkeeping, if appropriate. Plants that do not demonstrate box production during an audit, shall inform the audit agency of box production within the following 6 months of the subsequent anniversary date so the audit can be conducted during box production. If no box production can be witnessed within this time period of the second year, an unannounced audit of any other certified products shall be conducted, and that plant will receive a conditional box certification in which conditional certification rules apply. The manufacturer must then pay for an additional one day audit when box culvert production commences to retain certification and an audit must be conducted on the plant prior to boxes being shipped.
 4. A plant is awarded a conditional certification if receiving an overall score between 75 and 79.9. Plants receiving a conditional certification remain certified for the period of

- 6 months and can be certified until the next regular (unscheduled) annual audit if the following conditions are met:
- The manufacturer must correct deficiencies as stated in the Response to Deficiencies section of this manual. Every repeated deficiency will have a reduction of 0.25% points from the final score.
 - The manufacturer must perform an internal self-audit 6 months after receiving the audit report and send the results of that audit to both ACPA and the auditing agency.
5. Plant shall not be allowed to remain certified if it scores less than 80 overall or on the same Critical criterion in two consecutive audit years.
- Recertification of a manufacturer shall be accomplished by the same process and with equal rigor as the initial certification program. The manufacturer's plant must be found in acceptable compliance with this manual. The manufacturer must be found to maintain sufficient documentation to demonstrate compliance with guidelines. If the manufacturer's plant is again satisfactory, the manufacturer may retain the plaque and certificate of compliance.
 - ~~If the manufacturer receives a failing score during the audit, the manufacturer is removed from the certified list on the date the official report was issued from ACPA. Should the plant choose to appeal the audit report as per section "Appeal of Audit Results" of this manual they shall do so within 5 working days. If the appeal is unsuccessful, the manufacturer shall be decertified on the date the appeal case is closed. For manufacturers to reapply after a failed audit, they shall correct all deficiencies and show proof of sustainable compliance to QCast program. To regain certification the manufacturer shall re-submit an application, including payment, in US currency, for a re-audit within 30 days of receiving the audit report. The auditor shall schedule and conduct a re-audit within 60 days from the application date. If the manufacturer is unable to complete the re-audit satisfactorily, the plaque and certificate of compliance shall be returned to ACPA within 30 days.~~

Re-Audits

- Re-audits, due to audit deficiencies or incomplete elements. When notified of failing to pass an audit, the Manufacturer may request a re-audit. A request for re-audit shall be submitted, in writing, to ACPA and shall include a statement outlining the remedial action taken to correct previously reported deficiencies.
1. An auditor performing a re-audit due to audit deficiencies or incomplete elements shall re-audit all products that are to be certified at that plant, regardless of previous scores.
 2. A manufacturer's plant may fail the audit in two ways: 1) by receiving an overall audit score of less than 80, or 2) by receiving a score of less than 75 percent on any one of the identified critical audit elements.
 3. Plants shall not be allowed to remain certified if it scores less than 80 overall or on any individual critical criterion in two consecutive audit years.

4. A plant is awarded a conditional certification if receiving an overall score between 75 and 79.9. Plants receiving a conditional certification remain certified for the period of 6 months and can be certified until the next regular (unscheduled) annual audit if the following conditions are met:
 - The manufacturer must correct deficiencies as stated in the Response to Deficiencies section of this manual. Every repeated deficiency will have a reduction of 0.25% points from the final score.
 - The manufacturer must perform an internal self-audit 6 months after receiving the audit report and send the results of that audit to both ACPA and the auditing agency.
5. The manufacturer's plant shall not be granted certification until a re-audit has been completed successfully, and the manufacturer's plant has received a passing score. The date of the re-audit does not affect the plant's renewal date.
6. Expenses for the re-audit shall be borne wholly by the manufacturer.

Complaints

- Re-audits due to complaints.
If the ACPA receives a complaint, regarding suspected ACPA certification violations, a special Plant Certification Adjudication Task Group appointed by the ACPA Board of Directors shall take the complaint under consideration for possible action and re-audit. All information collected shall be treated as confidential to the extent allowed by the law. The need for actions and re-audits shall be determined on a case-by-case basis. Costs of re-audits due to justified complaints shall be borne by the ACPA.
- Customer complaints and resolutions
Maintain a file of all complaints relating to compliance with certification requirements and resolutions thereof. The file shall be made available to the auditor upon request.

Appeal of Audit Results

The appeal process has two stages for resolving disagreements. The first stage requires that the participating manufacturer submit a written appeal including substantiating information to ACPA within twenty (20) working days of receiving the audit report in question. The ACPA shall review the submittal and re-evaluate the audit findings. ACPA shall report, in writing, the results of the appeal within fifteen (15) working days of its receipt.

The second stage provides that an appellant, not satisfied with stage one resolutions, may appeal to the ACPA for relief. The appeal shall be referred to the Plant Certification Adjudication Task Group for action. An appeal must be made within 5 working days of receiving stage 1 appeal findings. The certification date of expiration shall extend through the appeal process. If a conflict of interest exists with a member or members of the special committee, alternates shall be appointed. The appointments shall be by the ACPA Chairman of the Board or the Vice-Chairman, in the Chairman's absence. The alternates shall be sitting

members of an ACPA committee (e.g., technical or marketing). Decisions by the Plant Certification Adjudication Task Group are final.

Notification Requirements

The manufacturer shall notify ACPA within 20 days for the following changes in:

- status of ownership
- quality management structure
- production process
- plant address
- major changes to the quality management system

Compliance Audit Conditions

By applying for QCast Certification, the Manufacturer enters into a contract with the ACPA for compliance with the production of quality precast concrete products and Gaskets. The information derived from the audits shall be reported to the Manufacturer to assist in continuous product improvement, and, if appropriate, to the ACPA for award of a compliance certificate.

Participation by the Manufacturer is wholly voluntary and has not been mandated to or forced on the Manufacturer in any manner by the ACPA. Certification shall indicate that, at the time of the audit, products were manufactured in compliance with this Manual's guidelines, and that sufficient documentation, tests, QA/QC procedures, and manufacturing controls existed to indicate continued compliance. The program makes no representations or warranties as to the quality of the products produced by the certified plant(s). The word "plant" describes any facility regularly engaged in the manufacture of products covered by this Manual.

The ACPA reserves the right to certify any manufacturer of precast concrete products and/or Gaskets who is located in North America, regardless of the Manufacturer's ACPA membership status. The ACPA in no way intends to restrict competition between ACPA members and non-members and offers participation in this program to any manufacturer.

When ACPA is required by law or authorized by contractual arrangements to release confidential information, the manufacturer concerned shall, unless prohibited by law, be notified of the information provided. Information about the manufacturer obtained from sources other than the manufacturer shall be treated as confidential.

Plant Certification Application

Visit www.concretepipe.org for a QCast application and a list of fees.

MANUFACTURER shall, for certified plants:

- Establish and maintain a high standard of integrity, skill and practice in order to produce products of sufficient quality to meet the Product Requirements of the ACPA QCast Plant Certification Manual and to comply with referenced ASTM standards for the production of those products.
- Establish and maintain product and material performance documentation and manufacturing practices that assure product is being produced in compliance with standards and guidelines.
- Supply only certified products from a certified plant to jobs requiring ACPA certified products.

In consideration of the mutual undertakings hereinafter set forth, and of ACPA entering into similar contracts with others, it is agreed between parties hereto as follows:

Eligibility. The Manufacturer's plant shall be engaged in the manufacturing of concrete products and/or Gaskets of the type for which the plant is being certified. The production process shall be available for audit by the third-party audit agency during the certification process.

The manufacturer makes claims regarding certification consistent with the scope of certification. Under no circumstances is a Manufacturer allowed to sell products manufactured in an uncertified plant as being from an ACPA certified plant. Product that is produced in a plant that is QCast certified (for a specific product) and it is not certified, cannot be claimed as a QCast certified product. Any products received from a non-certified plant shall be segregated from ACPA certified inventory. The manufacturer does not use its product certification in such a manner as to bring QCast program into disrepute and does not make any statement regarding its product certification that QCast program may consider misleading or unauthorized. Misuse of the ACPA certification in this manner shall be grounds for immediate remission of certification of the Manufacturer's certified plant. The Manufacturer has the option of appealing the remission of certification or re-application.

Audit Agency. Audits shall be conducted by a third-party Audit Agency selected and appointed by the ACPA. The ACPA retains sole authority for selection and appointment of the Audit Agency.

Audit. The ACPA shall arrange for all audits.

1. The Manufacturer shall pay for audit services for each plant according to the fees established by the ACPA.
2. The initial audit shall be scheduled on a mutually agreed upon date between the auditor and the manufacturer. The Manufacturer shall arrange for all elements requiring certification to be audited. Audits shall be conducted on dates established by the Audit Agency, except in the case of re-audit of a plant. Re-audit dates shall be established at the request of the Manufacturer with consideration of the Audit Agency's availability.

3. The applicant shall have all elements available for the auditor's inspection. The plant shall notify the ACPA of any scheduled shutdowns on the application form. Failure to notify both agencies of shutdowns which may affect the audit may result in a re-audit of the plant at the expense of the Manufacturer.
 4. The Manufacturer agrees to provide full cooperation with the Audit Agency, ACPA, and their employees or agents. If in the course of performing the audit it is discovered that the Manufacturer is withholding information, falsifying documentation, operating in an unsafe manner or obstructing the audit in any way, the Audit Agency, at its discretion, may terminate the audit and notify the Manufacturer that it is recommending to the ACPA, that the Manufacturer be disqualified.
 5. Additional audits or re-audits are available on request of the Manufacturer on a cost as billed basis.
- **Notification Procedure.** At the conclusion of the plant audit, the auditor will provide immediate feedback of the audit findings during an exit meeting with plant staff. Plants should arrange for available management and quality staff responsible for QCast to attend the exit meeting. The auditor will discuss the findings of the audit with plant staff and allow plant staff to provide any clarifications or additional supporting documentation. The exit meeting allows for plant staff to immediately address any needed improvements. Subsequently, the audit findings will also be provided in a written report to the ACPA and plant that will include the plant grading score. The audit reports shall not be released or published by the ACPA or the Audit Agency, and shall be kept confidential to the extent allowed by the law between those directly involved in the certification and appeals process. Upon written request the Audit Report may be shared by ACPA with the requesting SHA in the plant's market area, the plant retains the right to withdraw this permission and may do so at any time with a written notice to the ACPA. Any questions or correspondence by the Manufacturer relating to the report shall be directed in writing to the ACPA. The ACPA shall keep on file a copy of the three (3) most recent audit reports.
 - **Response to Deficiencies.** The manufacturer must correct deficiencies as stated in the auditor's findings and report actions taken to correct the deficiencies within 30 days of the audit report to the auditing agency. The auditing agency will review all audit responses to Deficiencies received by the plant and determine if response verifies conformance to QCast requirements. If the response conforms, the agency will issue a letter to the ACPA stating receipt and conformance. ACPA will review independent audit reports and responses to deficiencies and issue a letter confirming continued certification. If plant reply does not verify conformance, the agency will issue an email stating the remaining areas of non-conformance. The plant has additional 15 days to respond to remaining nonconformances from the date of notification. Plants unable to verify conformance to Deficiencies within the additional 15 days ~~or within 45 days of the audit report~~ will not remain certified by QCast. The ACPA will send email letter indicating QCast certification is forfeited.

- **Certification Symbols.** Upon certification, the Manufacturer shall receive a certificate of certification for display, and a reproduction proof of the certification emblem for use on stationary and in advertising.
 1. The certification certificate and reproduction proofs shall remain the property of the ACPA and shall be surrendered by the Manufacturer immediately in the event of loss of certification or voluntary withdrawal from the program. In such event, the Manufacturer agrees to immediately cease using all stationary and advertising literature bearing the certification symbol.
 2. Because of legal implications and the danger that the intent, scope, and application of the Compliance Audit Program may be inadvertently misrepresented, the Manufacturer shall obtain PRIOR WRITTEN APPROVAL FROM THE ACPA FOR ALL ADVERTISEMENTS OR PRINTED ANNOUNCEMENTS PERTAINING TO THE MANUFACTURER'S CERTIFICATION, OR THE ACPA CERTIFICATION PROGRAM.
- **Effective Date.** This contract shall become effective on the first day of the month following payment of the initial fees. The initial contract is written for a period of one (1) year.
- **Contract Renewal.** All renewal contracts shall be written for a one-year period. Contracts for renewal shall be mailed approximately sixty (60) days prior to expiration of current contract. No inspections shall be made without a completed contract, and the certification of a plant not under contract shall expire on the Manufacturer's respective quarter date.
- **Contract Cancellation.** Failure to comply with all provisions herein recorded shall result in this contract being subject to cancellation upon sixty (60) days written notice.
- **Ineligibility.** Failure to meet all contractual obligations mentioned in the bylaws section, financial or otherwise, prior to the expiration of this contract, may result in Manufacturer's termination and ineligibility to participate for a one (1) year period. Upon withdrawal or termination of certification, the manufacturer discontinues its use of all advertising matter that contains any reference thereto and takes action as required by the QCast certification program and takes any other required measure. Ineligibility shall start on the de-certification date. During this period, the Manufacturer shall not be considered for participation in the ACPA Compliance Audit Program. Payment of all contractual obligations to the ACPA under this contract shall be mandatory before application for re-certification may be made.
- **Certification Documents.** If the producer provides copies of the certification documents to others, the documents shall be reproduced in their entirety.

SECTION I

COMMON PROGRAM REQUIREMENTS

The ACPA Concrete Pipe, Manhole, Box Culvert and Engineered Precast Products, and Gaskets Certification Program requires that documentation files be maintained in each plant, as described in this section. A plant is allowed to have testing required by this Manual to be performed at a central plant of the same company as long as that plant is QCast certified. The individual plant shall receive the same score that the central test plant received on their audit for any requirements met by that central plant. All QC documentation files shall be retained for the previous three calendar years plus year-to-date, unless otherwise specified. For initial certification, a minimum of two months of documentation is required. Documentation may be paper or electronic files.

For the purposes of this Manual, "Annual" is defined as once per year with no more than 13 months in between.

1. Quality Documentation, Specifications and Information

The file shall contain a current copy of the following:

1.1. Company/Plant Quality Control Manual

Maintain a quality manual which describes in detail the policy on quality and the quality management structure. Describe or refer to standard industry procedures which constitute the working quality system. The manual documentation must either contain all necessary technical information for carrying out the plants quality systems or must make clear where the relevant information is to be found. Describe the document control system in the quality manual. The manual's emphasis must be as a source of reference to enable all staff to work properly and consistently. Maintain all plant quality records in such a way that they can be easily retrieved. The manual and standard QC documentation (control documents) shall have a version number and/or the date of the current version so that the most recent version can be clearly distinguished.

1.2. Current ACPA QCast Plant Certification Manual

1.3. Current Applicable ASTM Standards

1.3.1. Required ASTM Standards

A list of Required Standards and Documents is included in Appendix A, starting page 54.

1.3.2. Recommended Standards and Documents (As required by local specifications or product mix)

A list of Recommended Standards and Documents is included in Appendix A, starting page 58.

1.4. Documentation for Special Project Specifications

These documents shall contain specifications for projects which have different test methods or criteria than those required by this program.

1.5. Management Structure and Quality Control Coordinator

Identify a management structure that oversees the areas of accountability relating to quality control. The plant's management has the obligation to ensure that activities are conducted in accordance with the requirements of the plant's quality system. Each plant shall designate a Quality Control Coordinator and Back-up QC Coordinator who are responsible for the plant's quality control program. Each plant shall have a chart that identifies the areas of accountability relating to quality control and that lists the name of the individual(s) responsible for each QC function including final product inspection. A sample chart is shown in Appendix A, page 60. This chart should be modified as needed to properly align with plant QC operations. It shall be reviewed and updated at a minimum of annually, or whenever personnel changes are made.

The Quality Control Coordinator, having primary responsibility for the plants quality program and oversight of QC inspection and testing, is a key individual. Training documentation must be maintained for the Primary QC Coordinator and Backup QC Coordinator. If the primary QC Coordinator leaves their position for any reason, the plant must notify the ACPA within 20 days, and provide the name of the new QC Coordinator including records of applicable training and a revised QC Organizational chart. If a new QC Coordinator is not immediately available, provide a plan for interim QC oversight and follow-up documentation to be provided when a new QC Coordinator is trained and assigned.

1.6. Quality Authority / Hold Production Policy

The plant shall have on file a statement describing the authority of personnel to correct and/or stop production when quality issues arise, and to reject products not meeting requirements. This shall include a description of the authority to prevent product from being poured until after action has been taken to correct issues found during the pre-pour inspection process described in paragraph 8 of each product-specific requirement Section.

1.7. QC Meetings

Each plant shall hold a quality control meeting at a minimum of once every six (6) months. Attendees shall include supervisory, quality control and production personnel. Each plant shall maintain personnel training records, including the minutes from training meetings and training given to quality control personnel.

1.8. QC Personnel Training

Each plant shall have at least two individuals, Primary QC Coordinator and Backup QC Coordinator, who are currently accredited in one or more of the following: ACPA Quality School, or ACI Concrete Field Testing Technician Grade 1, or ACI Concrete Laboratory Testing Technician Level 1 or equivalent, (such as DOT Certified Concrete Quality Technician). One of these individuals shall be on staff during all production hours. These certifications shall be renewed every five years from the date of accreditation.

1.9. Quality Audits

Maintain a file containing all audits and reviews of the quality system, including records of corrective and preventative actions taken. The plant Quality Manager or other designated staff shall review QC documentation at least once every 30 days (monthly) and perform audits of the plant's quality system in addition to ACPA QCast audits. The audits may be done at least annually, but it is preferred if they are performed on a rolling basis such that in any one year each aspect of the quality system is covered at least once. Maintain audit procedures and checklists in the plant quality manual. Document the need for any corrective or preventative actions. Maintain all QCast audit reports for a minimum of three calendar years.

2. Materials

The following documents shall be maintained at the specified frequency during the months the plant is producing. If more than one supplier is used, the documents shall be obtained from all suppliers.

| Materials | Documents/Specifications | Frequency |
|------------------|---|--|
| Cement | Mill Certification | One per month for each type |
| Aggregate | ASTM C 150 Supplier provided Certification of Compliance (ASTM C 33) w/o Gradation. | Annual for each material |
| Aggregate | In-house, supplier, or third party gradation | Quarterly for each material. Monthly for box culvert. |
| Fly Ash | Supplier Test Report | One per month |

| | | | |
|---|--|----------|--|
| Other Cementitious Material Admixtures ¹ Reinforcing | ASTM C 618 Certifications Reports Certifications Mill Certifications | and Test | One per month for each material Annual for each material Annual for each type of product |
| Gasket Material Joint Sealant | Certifications ASTM C1619 Certifications | | Annual for each gasket type Annual for each sealant type |
| Pipe to Manhole Seals | Certifications | | Annual for each gasket type |

¹ For reinforced concrete products admixtures shall not contain calcium chloride.

3. Calibration

Maintain documentation verifying that production and testing equipment has been properly and accurately calibrated in accordance with local standards, with the following minimum frequency:

| Equipment | Calibration Document | Frequency |
|--|--------------------------------------|--------------------------|
| Batch Plant Scales ¹ | Independent ³ | Annual |
| Water Meter ¹ | In-house | Annual |
| Admixture Dispensing Equip. ¹ | In-house or Supplier | Annual |
| Concrete Compression Tester | Independent Cert. ³ | Annual |
| Three-Edge-Bearing Tester | Independent Cert. ³ | Annual |
| Go/No-Go Gauges | In-house | Annual |
| Laboratory Scales ¹ | In-house | Annual |
| Micrometers | In-house | Annual |
| Calipers | In-house | Annual |
| Vacuum Test Equip. | In-house | Annual |
| Hydrostatic Test Equip. | In-house | Annual |
| Air Content Test Equip. | In-house | Annual Quarterly for Box |
| Curing Temperature Logging Equipment ² | In-house Verification | Annual |
| <u>Hydraulic Rams (used for QCast sanitary certification test)</u> | <u>Independent Cert.³</u> | <u>Annual</u> |

¹ Calibrate in excess of maximum batch quantities. Scale accuracy should be verified using certified field standard weights to not less than 10 percent of the scale capacity. Material may then be substituted for the test weights. Substituting a load means that the certified field standard weights are removed from the scale and an equivalent weight of material is batched on the scale. The certified field standard weights can then be added back on the scale to calibrate the next increment of the scale use range. Calibrate batching scales in accordance with ASTM C1837 or C94 through the full working range with at least one calibration increment within each quarter of the scale working range. Document procedures for all non-standard calibration procedures used.

² Verification of temperature logging equipment shall include at least two points that exceed the expected product temperature range (EX 40°F 160°F). Verify that loggers are within ± 2°F.

³ Fully equipped to calibrate equipment to N.I.S.T. traceable data.

Calibration stickers shall be attached to each piece of equipment showing date of most recent calibration and date when the next calibration is due, including in-house calibrations.

4. Mix Designs

Maintain file copies of all mix designs. Designs shall be current and the same as those being used in production. Designs shall confirm a maximum water/cementitious material ratio in accordance with current ASTM requirements, with the exception that concrete used in severe weathering regions as defined by ASTM C33 Figure 1, shall confirm a maximum 0.45 W/C ratio for box culverts and 0.50 W/C ratio for pipe. Concrete Mix Design Data is included in Appendix A page 61.

4.1. Water

Water used in the production of concrete and for concrete curing shall be potable or non-potable water that meets the requirements of ASTM C 1602 Standard Specifications for Mixing Water Used in the Production of Hydraulic Cement Concrete.

4.2. Water/Cementitious Material Confirmation

For each concrete mix design produced, the water/cementitious ratio (w/c) shall be confirmed on actual batch weights a minimum of once per month. Aggregate moisture shall be determined according to ASTM C566. A discussion of this procedure and sample calculations are included in Appendix A, page 63 and page 64.

4.3. Concrete Batch Reports

4.3.1. In-Plant Batching

A minimum of one batch report showing the quantities of all ingredients for one batch shall be documented and maintained on file for each mix design produced each day.

4.3.2. Ready Mix Concrete

Truck delivery receipts listing mix proportions and quantities of all materials, including total water at time of placing, shall be received with each load and maintained on file. The supplier of ready mix concrete shall be local DOT or NRMCA certified. A current supplier certificate shall be maintained on file for each year that supplier delivered product to the plant.

4.4. Self-Consolidating Concrete (SCC)

The plant shall have on file a written quality control plan for SCC. The plan shall include a description of the test methods as well as the frequency and requirements for the results of those tests.

4.5. Flowable Concrete

Flowable concrete is concrete that is more workable than conventional concrete and will flow to fill formwork under its own mass, yet still requires vibration to ensure complete consolidation. Flowable concrete ranges from a 14"-22" slump flows. Additional requirements for testing of flowable concrete are included in Section 9 of this manual.

5. Joints

5.1. Joint Design Drawings

(see applicable product certification requirements in Sections II through V.)

5.2. Joint Design Calculations

(see applicable product certification requirements in Sections II through V.)

5.3. Spigot Go/No-Go Gauge (or optional measuring system)

(see applicable product certification requirements in Sections II through V.)

5.4. Gasket Quality

(see applicable product certification requirements in Sections II through VI)

A plant is allowed to have gasket testing required by this Manual to be performed by a QCast Certified Gasket Manufacturer. The gasket manufacturer shall provide the plant all QC testing records for each gasket shipment to the plant. All QC documentation files shall be retained for the previous three calendar years plus year-to-date, unless otherwise specified. Documentation may be paper or electronic files.

5.4.1. Testing Frequency

(see applicable product certification requirements in Sections II through VI.)

5.4.2. Gasket Q.C. Test Procedures

Testing procedures and a sample form are included in Appendix A, starting on page 65.

5.4.2.1. 5.4.2.1 O-Ring Gaskets

All sampled o-ring gaskets shall be tested for splice strength, gasket volume, cord diameter, gasket length and gasket hardness (durometer) (gasket volume should only apply to confined gaskets).

5.4.2.2. Profile Gasket

All sampled solid, profile gaskets shall be tested for splice strength, hardness (durometer), length, height, cut length and width. Gasket volume shall be tested for gaskets used in a confined recess or groove only.

5.4.2.3. Pre-lubricated Gaskets and Gaskets with Non-solid Cross Sections

All sampled pre-lubricated gaskets and gaskets with non- solid cross sections shall be tested for splice strength, cut length, height and width, and gasket hardness (durometer).

6. Equipment

(see applicable product certification requirements in Sections II through V.)

7. Reinforcing

Plants shall abide by all Buy America Provisions as specified by federal, state, and/or local requirements.

(see applicable product certification requirements in Sections II through V.)

8. Pre-Pour Inspection

8.1. Welded Splice Pull Test

Complete and record welded splice pull testing for laps that are required to be welded in accordance with applicable ASTM specifications. Complete this testing annually on a minimum of two samples, one on wires W5 and smaller and one on wires larger than W5.

(see applicable product certification requirements in Sections II through V.)

9. Concrete Testing

Fresh concrete shall meet all applicable specifications. Records of the testing shall be maintained on file. Concrete not meeting specifications shall not be used in production of certified products.

For material testing that is performed in-house, a backup plan is required for the case when testing cannot be performed based on current practices.

If any fresh concrete test (Sections 9.1-9.9) fails to meet all applicable specifications, the mix shall be adjusted within the parameters of the mix design. All applicable plastic concrete testing shall be redone to verify the concrete meets specifications.

9.1. Slump/Slump Flow Test of Wet Cast Concrete

9.1.1. Slump Tests of Wet Cast Concrete (ASTM C 143)

Slump tests shall be performed daily at a minimum, on each wet cast mix design being used that day. A sample report is shown in Appendix A, page 102.

9.1.2. Slump Flow Test of Flowable Concrete (ASTM C 1611)

Slump Flow tests for flowable concrete shall be performed daily at a minimum, for each continuous pour (defined 9.4.1). A sample report is shown in Appendix A, page 102

9.1.3. Slump Flow Tests of SCC Concrete (ASTM C 1611)

Slump Flow tests for self-consolidating concrete shall be performed daily, on the first two batches and every fourth batch thereafter for each continuous pour, for each SCC mix design used. A sample reports is shown in Appendix A, page 102.

9.2. T_{20} - Relative Measure of Flow Rate and Viscosity SCC (ASTM C 1611)

For each slump flow test completed on SCC, the time it takes for the outer edge of the concrete to reach a diameter of 20 inches shall be timed with a stopwatch and recorded. A sample report is shown in Appendix A, page 102.

9.3. VSI Index Flowable & SCC (ASTM C 1611)

For each slump flow test completed on flowable or SCC, VSI Index shall be estimated and recorded. Concrete having a VSI greater than 1 shall not be used. A sample report is shown in Appendix A, page 102.

9.4. Air Content Tests

9.4.1. Air Content Tests of Fresh Wet Cast Concrete (ASTM C 231)

When required by specification, air content test reports shall be maintained for each concrete mix being used in production each day that

mix is used. Test frequency shall be performed at a minimum of one air test on the first batch of the day. The test location shall be at the point of placement.

Additional air tests shall be performed at a minimum frequency of one test per 50 continuous yards of concrete poured. A continuous pour is defined as succession of batches where less than one-hour elapses between consecutive batches of a single mix design.

If batching and mixing is interrupted by a batch of concrete (with a different mix design) being mixed between consecutive batches. This is considered a new pour and an air test shall be taken on the first batch following the different batch, unless documentation exists that switching batches does not affect air content beyond specified limits. A sample report is shown in Appendix A, page 102.

9.4.2. Air Content Tests for Flowable Concrete and SCC (ASTM C 231)

Air testing shall be completed as described in 9.4.1 except that: When filling the container for air and unit weight Concrete with slump flows less than 18" shall be rodded per ASTM requirements. Slump flows greater than 18" may be one continuous lift if permitted by local specifications.

9.5. Unit Weight Tests

9.5.1. Unit Weight Tests of Fresh Wet Cast Concrete (ASTM C 138)

Maintain a copy of unit weight test results at a minimum of one test per week on each wet cast mix used that week.

9.5.2. Unit Weight Test for Flowable Concrete and SCC (ASTM C 138)

Test and record unit weight at a minimum one per day on flowable concrete and SCC. If concrete is not air entrained maintain a copy of unit weight test results at a minimum of one test per week.

9.6. Temperature Tests (ASTM C 1064)

Temperature tests shall be taken at the same frequency that cylinders in Section 9.9 of this Manual are taken for dry cast methods, and at the beginning of any continuous pour for wet cast methods. A sample report is shown in Appendix A, page 102.

9.7. Concrete Absorption Test Results

Maintain a copy of absorption test results at a minimum of one test per year on the lowest cementitious content mix for each production method. Tests shall be performed according to ASTM C 497 Absorption Test Method A or B. Absorption shall not exceed 9% for Method A or 8.5% for Method B, except for sanitary sewer pipe and sanitary sewer manholes which shall not exceed 7.5% for Method A and 7% for Method B.

9.8. Out-Sourced Concrete

For plants utilizing out-sourced concrete, the concrete shall conform to the requirements in Section 4 and Section 9 of Section I of this Manual.

9.9. Concrete Compression Tests (ASTM C 39)

Maintain copies of compression test results for all mixes used in production. For pipe that are three-edge bearing tested per Section 13 of this Manual, a minimum of 5 cylinders per week for each mix design used that week shall be prepared and tested. For pipe not required to be three-edge-bearing tested per Section 13 of this Manual, and all other products, a minimum of 5 cylinders per day per mix design used shall be prepared and tested. For box culvert production, an additional minimum of 2 cylinders per week shall be cast and tested to verify adequate stripping/handling strengths are being achieved. Stripping strength cylinders shall be cured with the product, or in a like manner. A sample report is shown in Appendix A, page 103.

9.9.1. Compression Test Specimen for Machine Cast (ASTM C 497)

Compression tests determining concrete compressive strength for dry cast methods may be made on concrete cylinders compacted according to ASTM C 497 and cured in like manner as the product, or on cores drilled from the product. The manufacturer shall have a written test procedure for casting dry cast cylinders.

9.9.2. Compression Test Specimen for Wet Cast Methods (ASTM C 31)

Compression tests determining concrete compressive strength of wet cast concrete shall be made, according to ASTM C31, on standard rodded or vibrated concrete cylinders and cured in like manner as the product (unless otherwise specified by local or project specifications), or on cores drilled from the product. The Manufacturer shall have a written procedure for casting wet-cast cylinders.

9.9.3. Compression Tests on Concrete Cores

The method of obtaining cores, the number of cores, and acceptability of core compression test results shall be in accordance with ASTM C497 or C 42, or as determined by product or specification requirements.

10. Curing

Plants shall cure the product in accordance with the applicable ASTM product specification or other superseding requirements. Acceptable methods include steam curing, water curing (curing in an enclosed environment with an excess of 90% relative humidity), membrane curing, a combination of these methods, or another method approved by the project owner. Accelerated curing shall commence only after concrete reaches its initial set. Maximum concrete temperature shall be 160 degrees F with a maximum temperature rise of 40 degrees F per hour during heat curing. Each plant shall have a written procedure to ensure that the product is adequately cured prior to stripping and handling. If the procedure does not include the continuous temperature monitoring of each piece, it shall include the test data used to develop the policy. Also included in this procedure shall be specified minimum compressive strength for stripping and handling. Curing temperature and cycle shall be monitored at a minimum of one product or kiln each day or curing cycle. The curing temperature of each kiln or accelerated curing system with independent temperature control shall be monitored throughout each curing cycle. If multiple kilns share the same control system, then only one needs to be monitored.

11. Post-Pour Inspection

(see applicable product certification requirements in Sections II through VI)

12. Product Marking

Pipe, manholes, box culverts, engineered precast products and three-sided structures, and Gaskets shall be marked in accordance with the requirements of the applicable ASTM, ASCE, CSA, Project or local specification and with the "QCast" emblem signifying compliance with the ACPA program.

13. Product Testing

(Gasketed Boxes, Pipe and Manhole only - see applicable product certification requirements in Sections II through Section V.)

14. Storage, Handling, Shipping and Final Inspection

Products meeting the requirements of this Manual shall be referred to in this section as "acceptable products". Products failing to meet the requirements shall be referred to as "reject".

14.1. Handling and Storage

Acceptable products shall be handled and stored to prevent damage. Reject products that cannot be repaired shall be marked and stored separately.

For Pipe: The plant shall have a documented maximum stack height for each pipe, size and class produced.

For Box: The plant shall have a documented maximum stack height for each box and size produced.

For Manholes and Precast: The plant shall have a documented maximum stack height for each manhole, precast product, and size produced.

14.2. Shipping Policy

The plant shall have a written Shipping Policy that describes the criteria that shall be met, including compressive strength (and/or three-edge-bearing strength for pipe), before products can be shipped. The criteria stated in the Policy shall meet or exceed the requirements of the specifying agency.

14.3. Final Inspection

The plant shall have a written Final Inspection Procedure in place to inspect products before shipping. Included in this procedure shall be the position(s) of the person responsible for final inspection and a means of documenting that the inspection has been done. The designated personnel shall be knowledgeable in recognizing product deficiencies and have the authority to prevent shipping of products not meeting project requirements.

SECTION II

PIPE REQUIREMENTS

In addition to the Common Requirements in Section I of the ACPA's QCast Plant Certification Manual, the following requirements are required for Pipe Certification. A plant undergoing Pipe Certification should refer to both Section I and this section to fulfill certification requirements. A plant undergoing Sanitary Sewer certification shall be subject to the additional requirements for sanitary sewer as listed in this section. Sanitary Sewer certification shall apply to field tested pipe intended for a variety of applications including: sanitary, storm, dams, levies, irrigation, siphons etc.

1. Quality Documentation
(see Common Program Requirements in Sections I)
2. Materials
(see Common Program Requirements in Sections I)
3. Calibration
(see Common Program Requirements in Sections I)
4. Mix Design
(see Common Program Requirements in Sections I)
5. Joints
 - 5.1. Joint Design Drawings
 - 5.1.1. Gasketed Sanitary Sewer Pipe and Storm Sewer and Culvert Pipe

For gasketed joint designs, maintain on file a set of drawings with critical joint dimensions and tolerances. A sample joint data form showing required information is included in Appendix A, page 65.

- 5.1.2. Non-Gasketed Storm Sewer and Culvert Pipe

For non-gasketed joint designs, maintain on file a set of drawings with critical dimensions and tolerances. A sample Joint Data Form showing required information is included in Appendix A, page 66.

- 5.2. Joint Design Calculations - Sanitary Sewer Pipe

For each joint and gasket, maintain on file a set of design calculations showing critical data and allowable tolerances. A discussion of joint design and sample calculations are included in Appendix A, starting on page 68.

5.3. Spigot Go/No-Go Gauge (or optional measuring system) - Sanitary Sewer Pipe

For each different gasketed joint and size, maintain a drawing showing the design and dimensions of a gauging system for the gasket sealing surface of pipe spigots. A drawing of a sample gauge is included in Appendix A, page 74.

5.4. Gasket Quality

Maintain in-house reports verifying critical dimensions of gaskets.

5.4.1. Testing Frequency

All gasket shipments shall be sampled and tested at the following minimum frequency:

| Pipe Size | Frequency |
|------------------|------------------|
| 12" - 33" | 1/300 |
| 36" and larger | 1/100 |

5.4.2. Gasket Q.C. Test Procedures

See Common Program Requirements

6. Equipment

6.1. Forms

New and repaired equipment shall be inspected prior to pouring to ensure proper dimensions and function.

Forms shall be kept clean of concrete build-up and inspected after each use. Example forms for new and repaired equipment are included in Appendix A page 122 and 123.

6.2. Joint Forming Equipment Inspection

6.2.1. Gasketed Pipe Headers and Tongue Formers Inspection

Maintain incoming* and annual inspection reports on headers and tongue formers used in the production of sanitary sewer pipe, and incoming inspection reports on headers and tongue formers used in the production of gasketed storm sewer pipe. Incoming inspections shall be a detailed report on the entire header or tongue former. Annual inspections shall be a minimum of the sloped surface adjacent to or behind the snap ring for confined gasket joints, and the sloped surface which forms the gasket sealing surface for single offset joints. Incoming inspection reports shall

be kept on file as long as the headers and tongue formers are in use. Sample forms are included in Appendix A, starting on page 65.

* Incoming shall hereafter be defined as the date of original purchase.

6.2.2. Non-Gasketed Pipe Headers and Tongue Formers Inspection

Maintain incoming inspection reports on headers and tongue formers used in the production of non-gasketed pipe. Incoming inspections shall be a detailed report on the entire header or tongue former and kept on file as long as the headers and tongue formers are in use. Sample forms are included in Appendix A, starting on page 78.

6.2.3. Gasketed Pipe Pallet Inspection

Maintain incoming and annual inspection reports on pallets used in the production of sanitary sewer pipe, and incoming inspection reports on pallets used in the production of gasketed storm sewer pipe. Incoming inspections shall be a detailed report of the entire pallet, and annual inspection shall be a minimum of the surface that forms the gasket-sealing surface. Incoming inspection reports shall be kept on file as long as the pallets are in use. Sample forms are included in Appendix A, starting on page 78.

6.2.4. Non-Gasketed Pipe Pallets and Groove Formers Inspection

Maintain incoming inspection reports on pallets and groove formers used in the production of non-gasketed pipe. Incoming inspections shall be a detailed report on the entire pallet or groove former, and kept on file as long as the pallets and groove formers are in use. Sample forms are included in Appendix A, starting on page 78.

6.2.5. Truing Ring Inspection Reports - Sanitary Pipe

Maintain incoming and annual inspection reports on truing rings used in the production of sanitary sewer pipe, and incoming inspection reports on truing rings used in the production of gasketed storm sewer pipe. Incoming inspection shall be a detailed report of the entire truing ring and annual inspection shall be a minimum of the surface that maintains the gasket sealing surface. Incoming inspection reports shall be kept on file as long as the truing rings are in use. Sample forms are included in Appendix A, starting on page 78.

7. Reinforcing

Detailed design information, including cage diameter tolerances and minimum lap, shall be available in the reinforcing fabrication area for cages/reinforcement being fabricated. Steel reinforcing shall comply with the requirements of the project specifications. Plants shall maintain on file the following reinforcing design information:

- Mesh Style
- Cage Diameter (and Tolerance)
- Cage Length
- Steel Area - specified
- Cage Location in the Product Wall
- Cage Lap (welded or tied and minimum lap)
- Cage Diameter Bell (and Tolerance)
- Shear Steel

7.1. In-Plant Drawn Wire

Drawn wire testing shall be conducted in accordance with ASTM A1064 - Standard Specification for Carbon-Steel Wire and Welded Wire Reinforcement, Plain and Deformed, for Concrete. Incoming steel supplier certifications shall be maintained on file. All facilities which draw their own wire for use in reinforced concrete pipe shall perform the testing in-house or by a third party.

8. Pre-Pour Inspection

8.1. Reinforcing Inspection

Maintain reports documenting the inspection of reinforcing used for each size and class produced. At a minimum, measure and document one cage at the start of each production run, one cage at the start of each new shift after that, and one cage if any component or setting is changed. A sample form of the Reinforcing Inspection Sheet for Pipe is included in Appendix A, page 88. All information shown on the sample form is considered minimum requirements.

8.2. Pre-Pour Visual Inspection

For each pipe produced, visually inspect the following applicable items prior to pouring:

- Reinforcing Placement
- Handling Holes / Lifting Devices
- Tie-pin Holes
- Release Agent Application
- Form Cleanliness and Condition
- Plugs

8.3. Pre-Pour Dimensional Inspection

For each pipe produced inspect and document the following applicable items by a minimum of initialing the shop drawings.

Embedded items - location

Blockouts - size and location

9. Concrete Testing (see Common Program Requirements in Sections I)

10. Curing (see Common Program Requirements in Section I)

11. Post-Pour Inspection

The individual responsible for product quality shall personally check a portion of each day's production before and after patching or "finishing". This inspection shall show that the correct production and patching techniques are being used.

11.1. Finishing and Repairs

After tip-out, pipe products shall be repaired or "finished" as required, to ensure that they shall perform as designed. The plant shall have written procedures on file describing repair materials and repair procedures.

11.2. Pipe Barrel Visual Inspection

Criteria for inspection shall include, at a minimum, inspection for barrel cracks, slumping, voids, bleeding, exposed steel, cage twist, segregation, swedging, slabbing, and flashing. Refer to local specifications.

11.3. Dimensional Test Reports on Pipe Barrels

Measure and record the pipe length, diameter and wall thickness; and calculate and record the difference in length of two opposite sides at a minimum frequency of one per size per shift, except on low production wet cast wherethere the minimum frequency shall be a minimum of 1/100 pieces or once every 6 months. Pipe measured as a part of three-edge-bearing tests can be included to meet frequency requirements. Product Dimensional Inspection Instructions and Sample Product Dimensional Reports are included in Appendix A, page 104 and page 105.

Inspect the size and location of all embedded items and blockouts as required on shop drawings.

11.4. Pipe Joint Visual Inspection

Inspection shall include, at a minimum, the following:

Before patching, inspect joints for cracks, smoothness of the bell and spigot, and snap ring positioning and a uniform step in single offset joints.

After patching, inspect joints for patching technique and quality, smoothness of bell and spigot, and a uniform snap ring width and depth.

11.5. Dimensional Test Reports on Pipe Spigots - Sanitary Sewer

Maintain reports verifying dimensional checks of all gasketed sanitary sewer pipe spigot gasket-sealing surfaces. These reports may be results of Go/No-Go gauging, or other measuring method that indicates the number of pipes passing the inspection. Label results by date of manufacture.

12. Product Marking
(see Common Program Requirements in Section I)

13. Product Testing

Maintain results of tests and inspections on the finished product as described below:

13.1. Water Tightness of Pipe – Sanitary Sewer

Sanitary sewer pipe shall be tested as described below. Where pipe sizes and test methods overlap, either test method may be used.

| Size | Frequency | Method | Test Criteria |
|----------------|-----------|---------------------------------|--------------------------------|
| 12 - 36" Pipe | 100% | Vacuum Test | See Appendix A, page 110 & 111 |
| Or | | | |
| 12 - 36" Pipe | 100% | Hydrostatic Test | See Appendix A, page 114 |
| 42" and Larger | 1/100 | Vacuum Test (min. of 2) | See Appendix A, page 110 & 111 |
| Or | | | |
| 42" and Larger | 1/100 | Hydrostatic Test (min. of 2) | See Appendix A, page 114 |

13.2. Three-Edge-Bearing Testing of Pipe

Pipe shall be three-edge-bearing tested as described below. All three-edge-bearing tests shall be performed according to ASTM C 497.

A sample form showing required information is included in Appendix A, page 116.

13.2.1. Reinforced Round Pipe Three-Edge-Bearing Tests

Pipe shall be tested at the following minimum frequencies:

| Pipe Size | Class | Minimum Frequency* |
|------------------------|---------------------|------------------------------|
| 12 - 15" | Class V and below | 1/1000 pieces |
| 18 - 3 9 6" | Class IV and below | 1/800 pieces |
| 18 - 3 9 6" | Class V | 1/400 pieces |
| 42 - 60" | Class III and below | 1/400 pieces |
| 42 - 60" | Class IV and V | 1/200 pieces |
| 66" and larger | All Classes | As required by project specs |

*Minimum testing frequency as listed above, or one~~1~~ piece of pipe per year for each size and class of pipe manufactured during that year, whichever is more frequent. Three-edge-bearing tests are not required on sizes produced that are less than 100 pieces production per year, as long as the plant has proof of design testing and cylinders are cast and tested as per Section 9.9 (Compression Strength Testing).

All tested pipe shall be tested to a minimum of 100% of the 0.01" specified D-Load requirement, or 0.01" crack width, whichever occurs first, ~~except that at least annually, one piece of each size and class up to 60" tested.~~ For each size and class tested as specified above, a minimum of one test performed shall be tested to the ultimate D-Load.

When a test is performed for acceptance of a lot, at or beyond the normal shipping age specified in the plant's QC Manual, and the test results do not meet the D-load requirements specified in ASTM C76, action shall be taken as follows:

- The test shall be recorded and included in three-edge-bearing documentation files, and
- A minimum of two consecutive tests shall be performed, and pass, for acceptance of the lot, and
- The lot shall be held from release or shipping until this additional testing is performed

or

- The lot shall be re-graded to a lower class, of which the minimum D-load requirements specified in C76 have been met.

This additional testing for acceptance will not be required as a result of a test that does not meet the minimum D-load requirements specified in ASTM C76 when the testing performed is informational or investigative, typically prior to normal shipping age specified in the plant's shipping

policy. However, new testing shall be performed at a later age for acceptance as specified above.

13.2.2. Non-reinforced Round Concrete Pipe Three-Edge-Bearing Tests

Non-reinforced concrete pipe shall be tested to the required ultimate loads as specified in Table I of ASTM C14 or in ASTM C 985, whichever standard is applicable, at frequencies required by job or local specifications.

13.2.3. Arch and Elliptical Three-Edge-Bearing Tests

Three-edge-bearing tests shall be performed according to ASTM C497 at frequencies required by job or local specifications.

13.2.4. Direct Design Concrete Pipe Three-Edge-Bearing Tests

Direct design concrete pipe is designed for an installed condition with soil-pipe interaction and need not be tested for three-edge-bearing strength. Concrete cylinder compression test frequencies shall meet the requirements of 9.9 of this Manual.

13.3. Off-Center Joint Test - Sanitary Sewer

Maintain a proof of design test result for all pipe sizes and joint designs used for sanitary sewer pipe. The test records shall, at a minimum, record results on joints for each size pipe for the lowest class pipe produced. The test shall be run according to Appendix A, page 117 and page 118. These reports shall be retained as a permanent record, and updated as reinforcing designs and joint configurations are changed.

13.4. Differential Joint Shear Test - Sanitary Sewer

For each pipe size and joint design, maintain a proof of design test result for the lowest concrete strength and lowest class of pipe produced. The test records shall at minimum, record results on joints for each size pipe for the lowest class pipe produced. These reports shall be retained for permanent record, and updated as reinforcing designs and joint configurations are changed. Test procedures and test criteria are included in Appendix A, page 119 and page 120.

13.5. Storm Sewer and Culvert Joint Test - Storm and Culvert

For all sizes of gasketed storm sewer and culvert pipe manufactured at the participating plant, the pipe manufacturer shall maintain proof of design test results. The reports shall be retained for permanent record, and updated as joint

design or gaskets are changed. Test procedures and test criteria are included in Appendix A, page 121.

14. Storage, Handling, Shipping and Final Inspection
(see Common Program Requirements in Section I)

SECTION III

MANHOLE REQUIREMENTS

In addition to the Common Requirements in Section I of the ACPA's QCast Plant Certification Manual, the following requirements are required for Manhole Certification. A plant undergoing Manhole Certification should refer to both Section I and this section to fulfill certification requirements.

1. Quality Documentation, Specifications and Information
(see Common Program Requirements in Section I)
2. Materials
(see Common Program Requirements in Section I)
3. Calibration
(see Common Program Requirements in Section I)
4. Mix Design
(see Common Program Requirements in Section I)
5. Joints

- 5.1. Joint Design Drawings

- 5.1.1. Sanitary Manholes

For each joint design, maintain on file a set of drawings with critical joint dimensions and tolerances. A sample joint data form showing required information is included in Appendix A, page 65

- 5.1.2. Storm Sewer and Culvert Manholes

For both gasketed and non-gasketed joint designs, maintain on file a set of drawings with critical dimensions and tolerances. A sample Joint Data Form showing required information is included in Appendix A, page 65 and page 66.

- 5.2. Joint Design Calculations - Sanitary Manholes

For each gasketed joint and gasket, maintain on file a set of design calculations showing critical data and allowable tolerances. A discussion of joint design and sample calculations are included in Appendix A, page 68 thru page 73.

- 5.3. Spigot Go/No-Go Gauge (or optional measuring system) - Sanitary Manholes

For each different gasketed joint and size, maintain a drawing showing the design and dimensions of a gauging system for the gasket sealing surface of manhole spigots. A drawing of a sample gauge is included in Appendix A, page 74.

5.4. Gasket Quality

Maintain in-house reports verifying critical dimensions of gaskets.

5.4.1. Testing Frequency

All gasket shipments shall be sampled and tested at a minimum frequency of one per 100.

5.4.2. Gasket Q.C. Test Procedures See Common Program requirements

6. Equipment

6.1. Forms

New and repaired equipment shall be inspected prior to pouring to ensure proper dimensions and function.

Forms shall be kept clean of concrete build-up and inspected after each use.

Example forms for new and repaired equipment are included in Appendix A page 122 and 123.

6.2. Joint Forming Equipment Inspection

6.2.1. Gasketed Manhole Headers and Tongue Formers

Maintain incoming* and annual inspection reports on headers and tongue formers used in the production of sanitary manholes and incoming inspection reports on headers and tongue formers used in the production of non-sanitary manholes. Incoming inspections shall be a detailed report on the entire header or tongue former. Annual inspections shall be a minimum of the sloped surface adjacent to or behind the snap ring for confined gasket joints, and the sloped surface which forms the gasket sealing surface for single offset joints. Incoming inspection reports shall be kept on file as long as the headers and tongue formers are in use. Sample forms are included in Appendix A, starting on page 78.

* Incoming shall hereafter refer to the date of original purchase.

6.2.2. Non-gasketed Manhole Headers and Tongue Formers

Maintain incoming inspection reports on headers and tongue formers used in the production of non-gasketed manholes. Incoming inspection shall be a detailed report on the entire header or tongue former and kept on file as long as the headers and tongue formers are in use. Sample forms are included in Appendix A, starting on page 78.

6.2.3. Gasketed Manhole Pallet Inspection

Maintain incoming and annual inspection reports on pallets used in the production of gasketed sanitary sewer manholes, and incoming inspection reports on pallets used in the production of non-sanitary sewer man- holes. Incoming inspections shall be a detailed report of the entire pallet, and periodic inspections shall be a minimum of the sloped surface that forms the gasket-sealing surface. Incoming inspection reports shall be kept on file as long as the pallets are in use. Sample forms are included in Appendix A, starting on page 78.

6.2.4. Non-gasketed Manhole Pallets and Groove Formers Inspection

Maintain incoming inspection reports on pallets and groove formers used in the production of non-gasketed manholes. Incoming inspection shall be a detailed report on the entire pallet or groove former, and kept on file as long as the pallets and groove formers are in use. Sample forms are included in Appendix A, starting on page 78.

6.2.5. Truing Ring Inspection Reports - Sanitary Sewer Manholes

Maintain incoming and annual inspection reports on truing rings used in the production of sanitary manholes, and incoming inspection reports on truing rings used in the production of gasketed storm sewer pipe. Incoming inspection shall be a detailed report of the entire truing ring and annual inspection shall be a minimum of the surface that maintains the gasket sealing surface. Incoming inspection reports shall be kept on file as long as the truing rings are in use. Sample forms are included in Appendix A, starting on page 78.

7. Reinforcing

Detailed design information, including cage diameter tolerances and minimum lap, shall be available in the reinforcing fabrication area for cages/reinforcement being fabricated. Steel reinforcing shall comply with the requirements of the project specifications. Plants shall maintain, on file, the following reinforcing design Information:

- Mesh Style
- Cage Diameter (and Tolerances)
- Cage Length
- Steel Area - specified
- Cage Location in the Product Wall
- Cage Lap (welded or tied, and minimum lap)
- Bell Reinforcing (convoluted or hoop)

8. Pre-Pour Inspection

8.1. Reinforcing Inspection

Maintain reports documenting the inspection of reinforcing used for each size produced. At a minimum, measure and document one cage at the start of each production run, one cage at the start of each new shift after that, and one cage if any component or setting is changed. A sample form of the Reinforcing Inspection Sheet for Manhole is included in Appendix A, page 89. All information shown on the sample form are considered minimum requirements.

8.2. Pre-Pour Visual Inspection

For each manhole produced, visually inspect the following applicable items prior to pouring:

- Reinforcing Placement
- Handling Holes / Lifting Devices
- Release Agent Application
- Form Cleanliness and Condition
- Step Holes / Plugs

8.3. Pre-Pour Dimensional Inspection

For each manhole produced, inspect and document the following applicable items by a minimum of initialing the shop drawings.

- Embedded items - location
- Blockouts - size and location

9. Concrete Testing (see Common Program Requirements in Section I)

10. Curing (see Common Program Requirements in Section I)

11. Post-Pour Inspection

The individual responsible for product quality shall personally check a portion of each day's production before and after patching of "finishing". This inspection shall show that the correct production and patching techniques are being used.

11.1. Finishing and Repairs

After tip-out, manhole products shall be repaired or "finished" as required, to ensure that they shall perform as designed. The plant shall have written procedures on file describing repair materials and repair procedures.

11.2. Manhole Visual Inspection

Criteria for inspection shall include, at a minimum, inspection for barrel cracks, slumping, voids, bleeding, exposed steel, cage twist, segregation, swedging, slabbing, and flashing. Refer to local specifications.

11.3. Dimensional Test Reports on Manholes

Measure and record the manhole length, diameter and wall thickness; and calculate and record the difference in length of two opposite sides at a minimum frequency of one per size per shift, except on low production wet cast there the minimum frequency shall be a minimum of 1/100 pieces or once every 6 months. Product Dimensional Inspection Instructions and Sample Product Dimensional Reports are included in Appendix A, starting on page 104.

Inspect the size and location of all embedded items and blockouts as required on shop drawings.

11.4. Manhole Joint Visual Inspection

Inspection shall include, at a minimum, the following:

Before patching, inspect joints for cracks, smoothness of the bell and spigot, and snap ring positioning and a uniform step in single offset joints.

After patching, inspect joints for patching technique and quality, smoothness of bell and spigot, and a uniform snap ring width and depth.

11.5. Dimensional Test Reports on Manhole Spigots - Sanitary Sewer

Maintain reports verifying dimensional checks of all gasketed sanitary sewer manhole spigot gasket-sealing surfaces. These reports may be results of Go/ No-Go gauging, or other measuring method that indicates the number of manholes passing the inspection. Label results by date of manufacture.

12. Product Marking

(see Common Program Requirements in Section I)

13. Product Testing

13.1. Water Tightness of Sanitary Sewer Manholes

Sanitary sewer manholes shall be tested as described below.

| Size | Frequency | Method | Test Criteria |
|----------------|-------------------|------------------|--------------------------------|
| 42" and Larger | 1/100 (min. of 2) | Vacuum Test | See Appendix A, page 110 & 111 |
| | Or | | |
| 42" and Larger | 1/100 (min. of 2) | Hydrostatic Test | See Appendix A, page 114 |

13.2. Manhole Step Testing

Maintain proof of design testing for manhole steps. Testing shall include pull out and load testing per the "Manhole Step Testing Methods" section of ASTM C497. Proof of design testing shall be completed and documented for each step design used in production. Tests shall be conducted on steps installed in manholes produced at the plant. If there is a change in production process or equipment, new tests shall be completed. Documentation shall include step identification, test results including maximum load applied, resulting vertical deflection, and minimum required loads, load cell or gauge calibration, and a description of the testing procedures.

In addition to proof of design tests on plant installed steps, maintain either:

1. Manufacturers certified test results performed within the past 3 years or
2. In-house test results every 3 years.

14. Storage, Handling, Shipping and Final Inspection
(see Common Program Requirements in Section I)

SECTION IV

ENGINEERED PRECAST PRODUCTS

In addition to the Common Requirements in Section I of the ACPA's QCast Plant Certification Manual, the following requirements are required for Engineered Precast Products Certification. A plant undergoing Engineered Precast Products Certification should refer to both Section I and this section to fulfill certification requirements.

1. Quality Documentation, Specifications and Information

1.1. Production Drawings

1.1.1. Standard Products

Standard product drawings, including reinforcing, critical dimensions and tolerances shall be maintained on file.

1.1.2. Non-Standard/Special Products

For products that vary from standard designs (including but not limited to, variations in hole size, embedment and/or reinforcement style/location, in- fall/outfall elevations, etc.), unique drawings including reinforcing, critical dimensions and tolerances shall be maintained on file.

2. Materials

(see Common Program Requirements in Section I)

3. Calibration

(see Common Program Requirements in Section I)

4. Mix Designs

(see Common Program Requirements in Section I)

5. Joints

Maintain detailed information on the joint and joint forming equipment.

6. Equipment

New and repaired equipment shall be inspected prior to pouring to ensure proper dimensions and function.

Forms shall be kept clean of concrete build-up and inspected after each use.

Example forms for new and repaired equipment are included in Appendix A page 122 and 123.

7. Reinforcing

Detailed design information, including cage dimensional tolerances and minimum lap, shall be available in the reinforcing fabrication area for cages/reinforcement being fabricated. Steel reinforcing shall comply with the requirements of the project specifications. Plants shall maintain, on file, the following reinforcing design information;

Reinforcing Style

Reinforcing Dimensions

Steel Area - specified

Reinforcing Location in the Product Wall

Reinforcing Lap Length (welded or tied)

Fiber Reinforcing - if fiber reinforcing is used, design information shall include fiber specification, size and quantity per cubic yard

Embedded steel location and connections

8. Pre-Pour Inspection

8.1. Pre-Pour Reinforcing Inspection

Initialing product shop drawings shall be the minimum documentation report.

A sample form of the Reinforcing Inspection Sheet for Precast is included in Appendix A, page 89.

8.1.1. Standard Products

Maintain reports documenting the inspection of reinforcing used for each specific design produced. At a minimum, measure and document one cage at the start of each production run, one cage at the start of each new shift after that, and one cage if any component or setting is changed.

8.1.2. Non-Standard Products

Maintain reports documenting the inspection of reinforcing used for each product being produced.

8.2. Pre-Pour Visual Inspection

For each product produced, inspect the following applicable items prior to pouring:

Form Release

Embedded Items

Form Cleanliness

Reinforcing Cover

8.3. Pre-Pour Dimensional Inspections

8.3.1. Standard Products

Maintain inspection records of all standard precast products form dimension at initial set-up for each production run. Documentation shall be a minimum of initialing product shop drawings.

8.3.2. Non-Standard Products

Maintain inspection records of all non-standard precast products form dimensions and blockout size and locations. Documentation shall be a minimum of initialing product shop drawings.

9. Concrete Testing (see Common Program Requirements in Section I)

10. Curing (see Common Program Requirements in Section I)

11. Post-Pour Inspection

The individual responsible for product quality shall personally check a portion of each day's production before and after patching or "finishing". This inspection shall show that the correct production and patching techniques are being used.

11.1. Finishing and Repairs

After stripping precast products shall be repaired or "finished" as required, to ensure that they shall perform as designed. The plant shall have a written repair procedure on file describing repair materials and repair procedure.

11.2. Visual Inspection

Criteria for inspection shall include, at a minimum, inspection for cracks, slumping, voids, bleeding, exposed steel, cage twist, segregation, swedging, slabbing and flashing.

11.3. Dimensional Test Reports

Inspect the size and location of all embedded items and blockouts as required on product drawings. Maintain a Post-Pour Dimensional Inspection Record of blockout and embedment dimensions on all precast products produced each day.

11.4. Joint Visual Inspection

Inspection shall include, at a minimum, the following:

Before patching, inspect joints for cracks, smoothness of the joint, and snap ring positioning and a uniform step in single offset joints. After finishing, inspect joints for finishing technique and quality.

12. Product Marking
(see Common Program Requirements in Section I)
13. Product Testing
(see Common Program Requirements in Section I)
14. Storage, Handling, Shipping and Final Inspection
(see Common Program Requirements in Section I)

SECTION V

BOX CULVERT AND THREE-SIDED STRUCTURE REQUIREMENTS

In addition to the Common Requirements in Section I of the ACPA's QCast Plant Certification Manual, the following requirements are required for Box Culvert and Three-sided Structures Certification. A plant undergoing Box Culvert and Three-sided Certification should refer to both Section I and this section to fulfill certification requirements.

1. Quality Documentation, Specifications and Information
(see Common Program Requirements in Section I)
2. Materials
(see Common Program Requirements in Section I)
3. Calibration
(see Common Program Requirements in Section I)
4. Mix Designs
(see Common Program Requirements in Section I)
5. Joints

5.1. Joint Design Drawings

Maintain detailed information on the joint and joint forming equipment. For each joint design, maintain on file a set of drawings showing critical joint dimensions and tolerances. A sample joint data form is included in Appendix A, page 66 for non-gasketed box culverts and three-sided structures. A sample joint data form showing required information for gasketed box culverts is included in Appendix A, page 67.

5.2. Joint Design Calculations - Gasketed Box Culvert

For each joint and gasket, maintain on file a set of design calculations showing critical data and allowable tolerances as required by ASTM C1677.

5.3. Spigot Go/No-Go Gauge (or optional measuring system) - Gasketed Box Culvert

For each different gasketed joint and size, maintain a drawing showing the design and dimensions of a gauging or measuring system for the gasket sealing surfaces.

5.4. Gasket Quality

Maintain in-house reports verifying critical dimensions of gaskets. Gaskets shall be sampled and tested at a minimum frequency of 1/25. Testing procedures and a sample form are included in Appendix A, page 75 and 77.

6. Equipment

New and repaired equipment shall be inspected prior to pouring to ensure proper dimensions and function.

Forms shall be kept clean of concrete build-up, and inspected after each use.

6.1. Joint forming Equipment Gasketed Box Culvert

Maintain incoming and annual inspection reports on non-segmented joint forming equipment used in the production of Gasketed Box Culverts.

Maintain incoming and “at the time of set-up” inspection reports on segmented joint forming equipment used in the production of Gasketed Box Culverts. Inspection reports showing required information are included in Appendix A, starting on page 84.

7. Reinforcing

Detailed design information including cage dimensional tolerances and minimum lap, shall be available in the reinforcing fabrication area for cages being fabricated. Steel reinforcing shall comply with the requirements of the project specifications.

7.1. Design

Reinforcing design information shall include:

Reinforced Areas Required

Reinforcing Design Area

Mesh Style or Rebar Size and Spacing

Reinforcing Lengths

Reinforcing Location in the Box Slab or Wall

Reinforcing Cover

Shear Steel

Laps

8. Pre-Pour Inspection

8.1. Reinforcing Inspection

Maintain reports documenting the inspection of reinforcing used for each specific design produced. At a minimum, measure and document one cage at the start of each production run, one cage at the start of each new shift after that, and one cage if any component or setting is changed. A sample form for Reinforcing Inspection Sheet is included in Appendix A, page 90 and page 91 for single cell box culverts, page 92 and page 93 for double cell box culverts, page 94 and page 95 for Three-Sided Structures with a flat deck, and page 96 and page 97 for Three-Sided Structures with an arch deck.

All information shown on the sample forms are considered minimum requirements.

8.2. Pre-Pour Visual Inspection

8.2.1. For each wet cast box culvert or three-sided structure produced, inspect and document the following applicable items prior to pouring.

Reinforcing orientation and spacing (top slab reinforcing shall be located in the top slab)

Form release

Embedded items

Form cleanliness

Reinforcing cover

8.2.2. For each dry cast box produced, a visual inspection of items listed under Section 8.2.1 is required. At a minimum, these inspections shall be documented on a once per shift basis.

8.3. Pre-Pour Form Dimensional Inspection

Maintain inspection records of all box culvert and three-sided structure section forms at initial setup for each product run. Required measurements include:

Thickness of top and bottom slab and both side walls

Core Rise

Core Span

Both core diagonal measurements

Skew of three-sided structure if applicable

Legs of three-sided structure, if applicable

Record measurements on "Box Culvert or Three-Sided Structure Pre-Pour/Pour Inspection" form. A sample of this form is included in Appendix A, page 98 for single cell box culverts, page 99 for double cell box culverts, page 100 for Three-Sided Structures with a flat deck, and page 101 for Three-Sided Structures with an arch deck.

9. Concrete Testing
(see Common Program Requirements in Section I)
10. Curing
(see Common Program Requirements in Section I)
11. Post-Pour Inspection

The individual responsible for product quality shall personally check a portion of each day's production before and after patching or "finishing". This inspection shall show that the correct production and patching techniques are being used.

11.1. Finishing and Repairs

After stripping, boxes and three-sided structures shall be repaired or "finished" as required, to ensure that they shall perform as designed. The plant shall have written procedures on file describing repair materials and repair procedures.

11.2. Visual Appearance

Inspect joint surfaces for cracks, smoothness of the bell and spigot, uniformity of joint sealing surfaces, and for visual defects, before and after patching.

All box culverts and three-sided structure shall be visually inspected for the following prior to yarding:

- Cracks
- Voids/bleeding
- Flashing
- Slumping
- Exposed Steel
- Surface Voids

Record results on "Box Culvert or Three-Sided Structures Post-Pour Inspection" form. Samples of these forms are included in Appendix A, page 106 for single cell box culverts, page 107 for double cell box culverts, page 108 for Three-Sided Structures with a flat deck, and page 109 for Three-Sided Structures with an arch deck. Refer to local specifications.

11.3. Dimensional Inspection

Maintain a Post-Pour Inspection Record on a minimum of 20% of all boxes and 100% of all three-sided structures produced each day from each form used that day (minimum one per form per day). Required measurements include:

Box Culverts:

Thickness of top and bottom slab and both side walls on both ends

Inside rise on both ends

Inside span on both ends

Inside length; top, bottom, both side walls, center wall for double-cell boxes

Three-Sided Structures:

Thickness of Deck and Precast Legs

Span of Precast Structure

Rise of Precast Structure

Width of Precast Structure Section

Record measurements on "Box Culvert or Three-Sided Structures Post-Pour Product Inspection" form. Samples of these forms are included in Appendix A, page 106 for single cell box culverts, page 107 for double cell box culverts, page 108 for Three-Sided Structures with a flat deck, and page 109 for Three-Sided Structures with an arch deck.

Inspect the size and location of all embedded items and blockouts as required on shop drawings.

Due to additional safety and quality concerns for box culverts that are produced with wetcast, flowable, or SCC concrete and that are stored and shipped vertically, dimensional measurements of the bottom end are not required provided that all form equipment was measured and inspected prior to the pour.

11.4. Dimensional Test Reports on Box Culvert Gasket Sealing Surfaces

Maintain reports verifying dimensional checks of gasketed sealing surfaces at a minimum rate of 1/25 or one per production run whichever is greater. These reports may be results of Go/No-Go gauging, or other measuring method that indicates the number of boxes passing the inspection. Label results by date of manufacture.

12. Product Marking (see Common Program Requirements in Section I)

13. Product Testing

Maintain Proof of design testing, in accordance with ASTM1677, for each size of gasketed box culvert manufactured.

14. Storage, Handling, Shipping and Final Inspection (see Common Program Requirements in Section I)

SECTION VI

GASKET REQUIREMENTS

In addition to the Common Requirements in Section I of the ACPA's QCast Plant Certification Manual, the following requirements are required for producers of rubber gaskets seeking Gasket Certification. A gasket manufacturing plant undergoing Gasket Certification should refer to both Section I requirements that are listed on the Gasket Grading Sheet and this section to fulfill certification requirements. This section of the QCast Manual is applied to gasket manufacturers and not precast manufacturers.

1. Quality Documentation, Specifications and Information
(see Common Program Requirements in Sections I)

Maintain all required ASTM, AWWA, and project standards for gaskets.

1.8. QC Personnel Training

There are presently no third-party quality training programs applicable for gasket manufacturing and inspection. Therefore, maintain training of quality control personnel through documented internal training activities. Gasket manufacturer shall monitor performance of QC personnel and take proper actions when the performance is not meeting expectation. Training needs of QC personnel shall be reviewed on annual basis. Document the review and perform the training accordingly.

2. Materials

Incoming Gasket Material Certs (Isoprene, Neoprene, Nitrile) per shipment

Rubber test data form suppliers per shipment

2.1. Material – Gasket Cord (purchased)

Gasket manufacturer producing gaskets from gasket cord shall maintain current (annual) materials certification letters available on file for gasket cord. Certification letters shall indicate compliance with the relevant specifications (such as ASTM C443 for profile gaskets, ASTM C361 for O-ring gaskets). Maintain mill certificates and rubber test data on file for each shipment or extrusion of gasket cord.

2.2. Material – Rubber Compound

Gasket manufacturer producing gaskets from rubber compound material shall ensure that Certificate of Analysis is available from raw material suppliers for each shipment. The Certificate of Analysis from the supplier shall be retained for one (1) year.

2.3. Material – Joint Lubricant

Maintain current (annual) material certification letters for joint lubricant materials and joint sealant materials, if supplied.

3. Calibration

(see Common Program Requirements in Section I)

| <u>Equipment</u> | <u>Calibration Document</u> | <u>Frequency</u> |
|--|--|-------------------------|
| <u>Gasket Inspection & Testing Equipment, calipers, etc.</u> | <u>In-house/external Verification / calibration report</u> | <u>Annual (Minimum)</u> |

Maintain calibration or verification reports for gasket inspection and testing equipment such as scales, measuring devices, durometers, etc. at least annually. Attach calibration stickers to all calibrated/verified equipment. Gasket splice tester shall be set up and verification performed and documented on each profile at the beginning of each run.

~~Measuring Instruments (Caliper, Scales, temperature gauges) annually
Testing Equipment (tensile tester, durometer, ozone tester) annually~~

3.4. Mix Design - Not applicable to gaskets.

5. Joints

5.4. Gasket Quality

Maintain in-house reports verifying critical dimensions of gaskets. Every gasket shall be tested for splice strength and documented at the minimum frequency listed below.

5.4.1. Testing Frequency

All gasket shipments shall be sampled and tested at the following minimum frequency:

| Pipe Size | Frequency | Box | Frequency |
|------------------|------------------|------------|------------------|
| 12" - 33" | 1/300 | All | 1/25 |
| 36" and larger | 1/100 | | |

5.4.2. Gasket Q.C. Test Procedures

Testing procedures and a sample form are included in Appendix A, starting on page 65.

5.4.2.1. 5.4.2.1 O-Ring Gaskets

All sampled o-ring gaskets shall be tested for splice strength, gasket volume, cord diameter, gasket length and gasket hardness (durometer) (gasket volume should only apply to confined gaskets).

5.4.2.2. Profile Gasket

All sampled solid, profile gaskets shall be tested for splice strength, hardness (durometer), length, height, cut length and width. Gasket volume shall be tested for gaskets used in a confined recess or groove only.

5.4.2.3. Pre-lubricated Gaskets and Gaskets with Non-solid Cross Sections

All sampled pre-lubricated gaskets and gaskets with non- solid cross sections shall be tested for splice strength, cut length, height and width, and gasket hardness (durometer).

6. Equipment

The gasket manufacturer shall establish and maintain a documented procedure for equipment maintenance and repair.

New and repaired equipment shall receive a documented inspection prior to use to ensure proper function. Equipment shall be kept clean and inspected prior to each use. (see common program requirements in Section I)

7. Reinforcing - Not applicable to gaskets.

8. Pre-Pour Inspection

At a minimum, measure and document the first two gaskets at the start of each production run, at the start of each new shift after that, and if any component or setting is changed. If the gaskets do not meet the product specifications, continue to test gaskets and document test results until three consecutive pieces conform. Alternate quality control procedures may be substituted that provide this minimum level of quality or better. Gaskets shall be sampled and tested at the minimum frequencies shown below. If a gasket fails the splice strength test, test 100 percent of the remaining lot (size) produced.

8.1. Gasket Production QC Testing Frequency

8.1.1. Gasket manufacturer producing gaskets from gasket cord minimum testing frequencies:

—

- Hardness at the start of each new reel.
- Cut length of first two pieces produced and at a minimum frequency of 1 per every 50 pieces thereafter.
- Cross-sectional dimensions (height and width for profile gaskets, diameter for o-ring gaskets) of first two pieces produced and at a minimum frequency of 1 per every 100 gaskets thereafter.
- Gasket volume (O-ring gaskets) of first two pieces produced and at a minimum frequency of 1 per every 50 gaskets thereafter.
- Splice strength of first two pieces produced and at a minimum frequency of 1 per every 100 pieces thereafter.

8.1.2. Gasket manufacturer producing gaskets from rubber compound minimum testing frequencies:

Cross section dimensions, hardness, cut length, splice strength, and volume (when applicable) shall be sampled and tested on the first two pieces produced and at a minimum frequency per the table below thereafter.

| Pipe Size | Frequency |
|------------------|------------------|
| 12" - 33" | 1/300 |
| 36" and larger | 1/100 |

Alternate quality processes that effectively evaluate gasket quality may be substituted that provide this minimum level of quality or better.

8.2. Production Control and In-Process Testing

8.2.1. Gasket manufacturer producing gaskets from gasket cord inspect and document the following:

- Store reels of gasket cord indoors and maintain properly labeling.
- Have process in place to use gasket cord on a first-in-first-out basis as practical. Allowable shelf life shall be defined for each material and a documented process will be on file to test and accept or reject product past the shelf life prior to use.
- Reject deficient cord or gasket pieces. Clearly mark or separate in marked bins rejected material.
- Check that equipment is properly setup and operational.
- Visually inspect gaskets for defects.
- Check that gasket markings are legible, complete, and durable.
- Store splice adhesives properly with correct labeling. Do not use adhesive past allowable shelf life.

- Ensure that in-process defective products are documented, segregated, identified and dispositioned as per defined documented procedures.

8.2.2. Gasket manufacturer producing gaskets from rubber compound inspect and document the following:

- Use rubber compound on a first-in-first-out basis, as practical.
- Store incoming material, in process and finished products indoors, and maintain proper labeling.
- Store splice tape properly with proper labeling.
- Ensure that manufacturing process (extrusion and fabrication) parameters are set up properly as per defined set up instructions.
- Visually inspect in-process products for defects.
- Check that gasket markings/printing logo are legible, complete, and durable.
- Store splice adhesives properly with correct labeling. Do not use adhesive past allowable shelf life.
- Ensure that in-process defective products are documented, segregated, identified and dispositioned as per defined documented procedures.

8.3. QC/Production Inspection

Document independent checks of gasket production at least once each shift. Develop and complete daily inspection checklist(s) for each shift. Persons not directly responsible for production and testing, such as the QC coordinator, production supervisors, or assigned trained designee shall confirm that production testing is performed adequately and is being documented at the required frequencies. Inspect and document the following as a minimum:

- All incoming reels of gasket cord or rubber compound is stored indoors and are properly labeled.
- Gasket cord or rubber compound used on a first-in-first-out basis, as a general practice. Material past shelf life is clearly marked and/or separated.
- Rejected cord or rubber compound is clearly marked and/or separated.
- Maintain documentation of gasket cord or rubber compound that is rejected and disposition of rejected material.
- Equipment is properly setup and operational.
- Gasket testing is being completed properly and at the required frequencies
- Gaskets are free of visual defects.
- Gasket markings are legible, complete, and durable.
- Splicing equipment is setup properly, verified, and operational.
- Splice adhesive or tape properly stored, labeled and within shelf life.
- Proper adhesive is being used.
- Splice testing is being performed properly and at correct frequency.
- Gasket repairs are being done properly and repaired gaskets are tested.

~~The first two consecutive gaskets shall be tested and documented for each new setup and checked against allowable tolerances. Additional tests shall be performed and documented until two gaskets meet all tolerances. Clearly mark or separate rejected gaskets.~~

9. Concrete Testing - Not applicable to gaskets.

10. Curing - Not applicable to gaskets.

11. Post-Pour Inspection

11.1. Finishing and Repairs

Repair procedures for gaskets shall be on file. If allowed, describe the process for reprocessing gaskets failing the splice strength test. Gasket splices are to be re-tested after repair.

Non-conforming product shall be marked and disposed of or clearly separated.

Repaired products that have passed splice strength testing shall go through final inspection as per Section 14.3.

~~After production, gasket products shall be repaired as required, to ensure that they shall perform as designed. The plant shall have written procedures on file describing repair materials and repair procedures~~

12. Product Marking

Gasket markings shall meet applicable ASTM requirements (ASTM C1619 unless otherwise specified) and be legible and durable. At minimum, markings shall include or indicate standard (ASTM) designation, size, gasket cross section if other than circular, class, rubber type (stripe), cut length or volume, date of manufacture, lot number, and manufacturer and plant identification.

~~Mark gaskets with: Name or trademark of gasket manufacturer, product size, gasket name or designation. Special gaskets shall be marked different from regular gaskets.~~

13. Product Testing – not applicable to gaskets

~~(see common program requirements on Section I)~~

14. Storage, Handling, Shipping and Final Inspection

(see Common Program Requirements in Section I)

Products meeting the requirements of this Manual shall be referred to in this section as “acceptable products”. Products failing to meet the requirements shall be referred to as “reject”.

14.1. Handling and Storage

Acceptable products shall be handled and stored to prevent damage. Reject products that cannot be repaired shall be marked and stored separately. Shipping containers shall be properly labeled, durable, and protected from damage.

14.2. Shipping Policy

Maintain a written Shipping Policy that describes the criteria that shall be met, before products can be shipped. The policy shall define minimum requirements for labeling and markings on the shipping boxes. Labels shall include the following minimum information: manufacturer, plant id, size, class, product type (if applicable) and company contact information.

Maintain a log of all returned product citing the cause for the return and the disposition. Maintain a return policy outlining procedures for inspecting, testing and reuse, or disposing of returned gasket shipments

14.3. Final Inspection

Maintain a written Final Inspection Procedure to inspect products before shipping. Included in this procedure shall be a means of documenting that the inspection has been done. Document the names of the designated personnel who are responsible for final inspection and knowledgeable in recognizing product deficiencies and have the authority to prevent shipping of products not meeting project requirements.

Quality control documentation shall be made available for each production lot either by hard-copy or be available electronically upon request. Producer plants must have easy access to quality control certification data meeting the minimum requirements of this QCast Manual for each lot received.

~~All gaskets shall be kept dry, protected from sun and heat and not intermixed with other gasket sizes or types~~

APPENDIX A: Procedures and Forms

Required ASTM/AASHTO Standards

For ACPA Pipe, Manhole, Precast Products, Box Culverts and Three-sided Structures, and Gaskets

| | |
|--------------|---|
| A 615/ M 31 | Specification for Deformed and Plain Billet-Steel Bars for Concrete Reinforcement |
| A 706 | Specification for Low-Alloy Steel Deformed and Plain Bars for Concrete Reinforcement |
| A 767 | Specification for Zinc-Coated (Galvanized) Steel Bars for Concrete Reinforcement |
| A 775/ M 284 | Specification for Epoxy-Coated Reinforcing Steel Bars |
| A 884 | Specification for Epoxy-Coated Steel Wire and Welded Wire Fabric for Reinforcement |
| A 1064 | Specification for Steel Wire and Welded Wire Reinforcement, Plain and Deformed, for Concrete |
| C 31 | Practice for Making and Curing Concrete Test Specimens in the Field |
| C 33 | Specification for Concrete Aggregates |
| C 39 | Test Method for Compressive Strength of Cylindrical Concrete Specimens |
| C 40 | Test Method for Organic Impurities in Fine Aggregates for Concrete |
| C 42 | Test Method for Obtaining and Testing Drilled Cores and Sawed Beams of Concrete |
| C 94 | Specification for Ready-Mixed Concrete |
| C 136 | Test Method for Sieve Analysis of Fine and Coarse Aggregates |
| C 138 | Test Method for Unit Weight, Yield, and Air Content (Gravimetric) of Concrete |
| C 143 | Test Method for Slump of Hydraulic-Cement Concrete |
| C 150/ M 85 | Specification for Portland Cement |
| C 172 | Practice for Sampling Freshly Mixed Concrete |
| C 173 | Test Method for Air Content of Freshly Mixed Concrete by the Volumetric Method |
| C 231 | Test Method for Air Content of Freshly Mixed Concrete by the Pressure Method |
| C 403 | Test Method for Time of Setting of Concrete Mixtures by Penetration Resistance |
| C 494/ M 194 | Specification for Chemical Admixtures for Concrete |
| C 497 | Test Methods for Concrete Pipe, Manhole Sections, or Tile |
| C 595/ M 240 | Specification for Blended Hydraulic Cement |
| C566 | Standard Test Method for Total Evaporable Moisture Content of Aggregate by Drying |
| C 618/ M 295 | Specification for Coal Fly Ash and Raw or Calcined Natural Pozzolan or Use as a Mineral Admixture in Portland Cement Concrete |
| C 805 | Test method for Rebound Number of Hardened Concrete |
| C 822/ M 262 | Terminology Relating to Concrete Pipe and Related Products |

| | |
|---------------|---|
| C 877 | External Sealing Bands for Non-Circular Concrete Sewer, Storm Drain and Culvert Pipe |
| C 923 | Specification for Resilient Connectors Between Reinforced Concrete Manhole Structures, Pipes, and Laterals |
| C 989/ M 302 | Specification for Ground Granulated Blast-Furnace Slag for Use in Concrete and Mortars |
| C 990/ M 198 | Specification for Joints for Concrete Pipe, Manholes, and Precast Box Sections using Preformed Flexible Joints Sealants |
| C 1064 | Test Method for Temperature of Freshly Mixed Portland Cement Concrete |
| C 1116 | Specification for Fiber-Reinforced Concrete and Shotcrete |
| C 1131 | Practice for Least Cost (Life Cycle) Analysis of Concrete Culvert, Storm Sewer, and Sanitary Sewer Systems |
| C 1240/ M 307 | Specification for Silica Fume Used in Cementitious Mixtures |
| C 1478 | Specification for Storm Drain Resilient Connectors Between Reinforced Concrete Storm Sewer Structures, Pipe, and Laterals |
| C 1602 | Standard Specification for Mixing Water Used in the Production of Hydraulic Cement Concrete |
| D 2240 | Test Method for Rubber Property - Durometer Hardness |

Required ASTM/AASHTO Standards for Pipe

(In addition to the required ASTM Standards shown above, the following are also required for Pipe Certification.)

| | |
|--------------|--|
| C 14/ M 86 | Specification for Concrete Sewer, Storm Drain and Culvert Pipe |
| C 76/ M 170 | Specification for Reinforced Concrete Culvert, Storm Drain and Sewer Pipe |
| C 118 | Specification for Concrete Pipe for Irrigation or Drainage |
| C 361 | Specification for Reinforced Concrete Low-Head Pressure Pipe |
| C 412/ M 178 | Specification for Concrete Drain Tilelection VI |
| C 443/ M 315 | Specification for Joints for Concrete Pipe and Manholes, Using Rubber Gaskets |
| C 444/ M 175 | Specification for Perforated Concrete Pipe |
| C 505 | Specification for Non-reinforced Concrete Irrigation Pipe with Rubber Gasket Joints |
| C 506/ M 206 | Specification for Reinforced Concrete Arch Culvert, Storm Drain and Sewer Pipe |
| C 507/ M 207 | Specification for Reinforced Concrete Elliptical Culvert, Storm Drain and Sewer Pipe |
| C 654/ M 176 | Specification for Porous Concrete Pipe |
| C 655/ M 242 | Specification for Reinforced Concrete D-Load Culvert, Storm Drain and Sewer Pipe |
| C 969 | Practice for Infiltration and Exfiltration Acceptance Testing of Installed Precast Concrete Pipe Sewer Lines |
| C 985 | Specification for Non-reinforced Concrete Specified Strength Culvert, Storm Drain and Sewer Pipe |

- C 1103 Practice for Joint Acceptance Testing of Installed Precast Concrete Pipe Sewer Lines
- C 1214 Test Method for Concrete Pipe Sewer Lines by Negative Air Pressure (Vacuum) Test Method
- C 1417 Specification for Manufacture of Reinforced Concrete Sewer, Storm Drain, and Culvert Pipe for Direct Design
- C 1479 Practice for Installation of Precast Concrete Sewer, Storm Drain, and Culvert Pipe Using Standard Installations

Required ASTM Standards for Manhole

(In addition to the required ASTM Standards shown above, the following are also required for Manhole Certification.)

- C 478/ M 199 Specification for Precast Reinforced Concrete Manhole Sections
- C 1244 Test Method for Concrete Sewer Manholes by the Negative Air Pressure (Vacuum) Test

Required ASTM Standards for Precast

(In addition to the required ASTM Standards shown above, the following are also required for Precast Certification.)

- C 1227 Specification for Precast Concrete Septic Tanks

Required ASTM/AASHTO Standards for Box Culverts

(In addition to the required ASTM Standards shown above, the following are also required for Box Culverts Certification.)

- C 1433 Specification for Precast Reinforced Concrete Box Culvert Section for Culverts, Storm Drains and Sewers
- C 1504 Specification for Manufacture of Precast Reinforced Concrete Three-Sided Structures for Culverts, and Storm Drains
- C 1577 Specification for Precast Reinforced Concrete Box Sections for Culverts, Storm Drains, and Sewers Designed According to AASHTO LRFD

Required ASTM/AASHTO Standards for Gaskets

- C 443/ M 315 Specification for Joints for Concrete Pipe and Manholes, Using Rubber Gaskets
- C 1619 Standard Specification for Elastomeric Seals for Joining Concrete Structures
- C 1677 Standard Specification for Joints for Concrete Box, Using Rubber Gaskets

Required ASTM/AASHTO Standards for Gasket Certification

| | |
|---------------------|---|
| <u>C 361</u> | <u>Specification for Reinforced Concrete Low-Head Pressure Pipe</u> |
| <u>C 443/ M 315</u> | <u>Specification for Joints for Concrete Pipe and Manholes, Using Rubber Gaskets</u> |
| <u>C 505</u> | <u>Specification for Non-reinforced Concrete Irrigation Pipe with Rubber Gasket Joints</u> |
| <u>C 1103</u> | <u>Practice for Joint Acceptance Testing of Installed Precast Concrete Pipe Sewer Lines</u> |
| <u>C 1619</u> | <u>Specification for Elastomeric Seals for Joining Concrete Structures</u> |
| <u>C 1628</u> | <u>Specification for Joints for Concrete Gravity Flow Sewer Pipe, Using Rubber Gaskets</u> |
| <u>C 1677</u> | <u>Standard Specification for Joints for Concrete Box, Using Rubber Gaskets</u> |
| <u>D 2240</u> | <u>Test Method for Rubber Property - Durometer Hardness</u> |
| <u>D 2527</u> | <u>Standard Specification for Rubber Seals - Splice Strength</u> |

Recommended Standards and Documents

For ACPA Pipe, Manhole, Precast Products, Box Culverts and Three-sided Structures, and Gaskets

(As required by Local Specifications or Product Mix)

| | |
|--------------|--|
| PCA | Manual for Design and Control of Concrete Mixtures |
| ACI 116 | Cement and Concrete Terminology |
| ACI 211.1 | Practice for Selecting Proportions for Normal, Heavyweight, and Mass Concrete |
| ACI 211.2 | Practice for Selecting Proportions for Structural Lightweight Concrete |
| ACI 211.3 | Practice for Selecting Proportions for No-Slump Concrete |
| ACI 302 | Guide for Concrete Floor and Slab Construction |
| ACI 304 | Guide for Measuring, Mixing, Transporting, and Placing Concrete |
| A 36 | Specification for Structural Steel |
| A 108/ M 169 | Specification for Steel Bars, Carbon, Cold-Finished, Standard Quality |
| A 184/ M 54 | Specification for Fabricated Deformed Steel Bar Mats for Concrete Reinforcement |
| A 615/ M 31 | Specification for Deformed and Plain Billet-Steel Bars for Concrete Reinforcement |
| A 616 | Specification for Rail-Steel Deformed and Plain Bars for Concrete Reinforcement |
| A 617 | Specification for Axle-Steel Deformed and Plain Bars for Concrete Reinforcement |
| C 70 | Test Method for Surface Moisture in Fine Aggregate |
| C 117 | Test Method for Materials Finer than 75 -um (No. 200) Sieve in Mineral Aggregates by Washing |
| C 123 | Test Method for Lightweight Particles in Aggregate |
| C 142 | Test Method for Clay Lumps and Friable Particles in Aggregates |
| C 192/ R 39 | Practice for Making and Curing Concrete Test Specimens in the Laboratory |
| C 231 | Test Method for Air Content of Freshly Mixed Concrete by the Pressure Method |
| C 260/ M 154 | Specification for Air-Entrained Admixtures for Concrete |
| C 330/ M 195 | Specification for Lightweight Aggregates for Structural Concrete |
| C 566 | Test Method for Total Evaporable Moisture Content of Aggregate by Drying |
| C 666 | Test Method for Resistance of Concrete to Rapid Freezing and Thawing |

| | |
|--------------|--|
| C 685/ M 241 | Specification for Concrete Made by Volumetric Batching and Continuous Mixing |
| C 857 | Practice for Minimum Structural Design Loading for Underground Precast Concrete Utility Structures |
| C 858 | Specification for Underground Precast Concrete Utility Structures |
| C 890 | Practice for Minimum Structural Design Loading for Monolithic or Sectional Precast Concrete Water and Wastewater Structures |
| C 913 | Specification for Precast Concrete Water and Wastewater Structures |
| C 915 | Specification for Precast Reinforced Concrete Crib Wall Members |
| C 936 | Specification for Solid Concrete Interlocking Paving Units |
| C 979 | Specification for Pigments for Integrally Colored Concrete |
| G 109 | Test Method for Determining the Effects of Chemical Admixtures of the Corrosion of Embedded Steel Reinforcement in Concrete Exposed to Chloride Environments |
| C 1227 | Specification for Precast Concrete Septic Tanks |
| C 1478 | Specification for Storm Drain Resilient Connectors Between Reinforced Concrete Storm Sewer Structures, Pipes and Laterals |
| C 1610 | Test Method for Static Segregation of Self-Consolidating Concrete Using Column Technique |
| C 1611 | Test Method for Slump Flow of Self-Consolidating Concrete |
| C 1618 | Test Method for Concrete Sanitary Sewer Pipe by Negative (Vacuum) or Positive Air Pressure |
| C 1619 | Specification for Elastomeric Seals for Joining Concrete Structures |
| C 1621 | Test Method for Passing Ability of Self-Consolidating Concrete by J-Ring |
| C 1628 | Specification for Joints for Concrete Gravity Flow Sewer Pipe, Using Rubber Gaskets |
| C 1677 | Standard Specification for Joints for Concrete Box, Using Rubber Gaskets |
| C 1837 | Standard Specification for Production of Dry Cast Concrete Used for Manufacturing Pipe, Box, and Precast Structures |

[AASHTO R73-Standard Practice for Evaluation of Precast Concrete Drainage Products](#)

ACPA Technical Management Structure

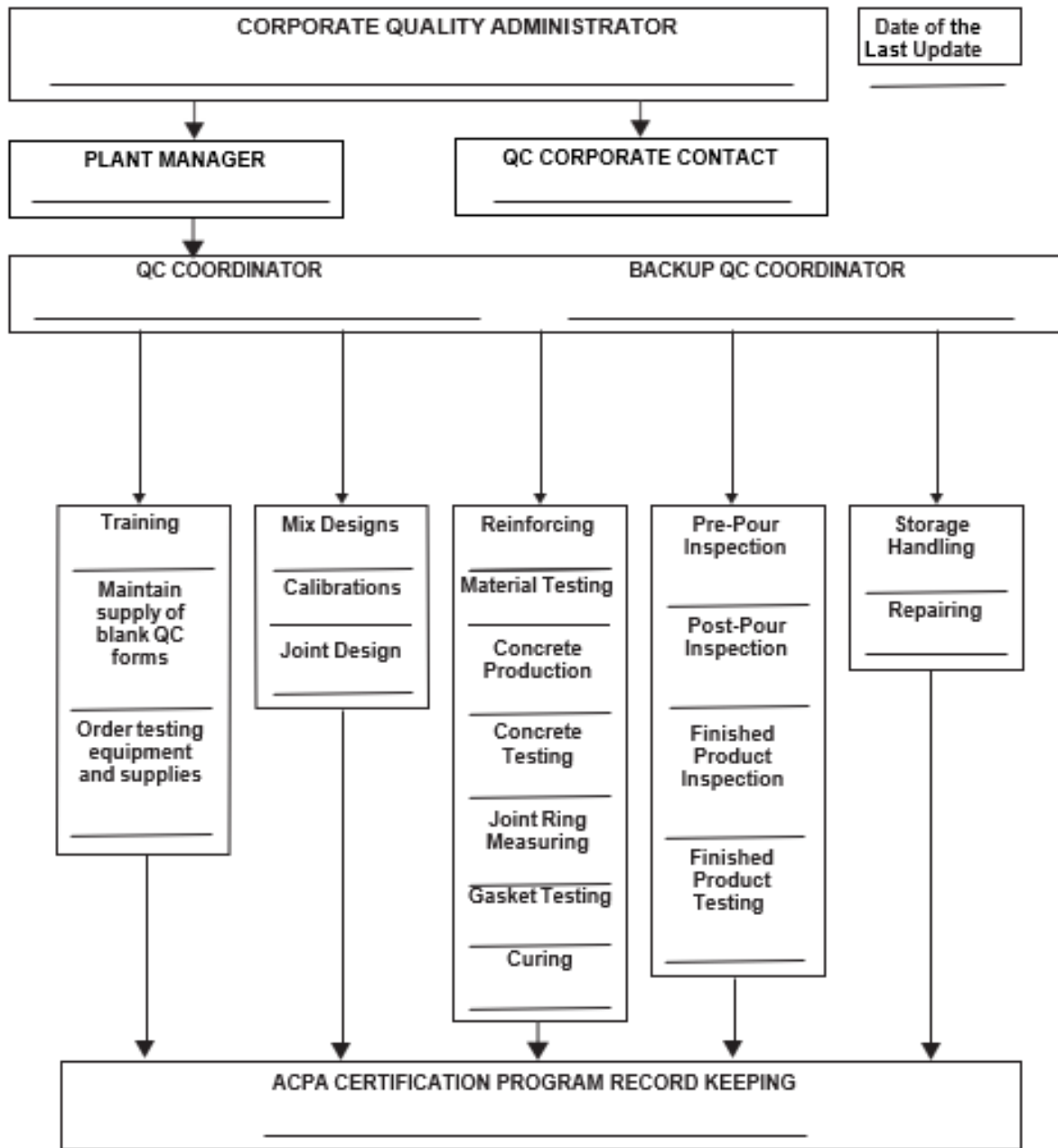

The name of the person responsible for each above duty, shall be placed on the corresponding line.

DATE UPDATED _____ SIGNATURE _____

Mix Design Template

Instructions: Fill in cells with mix specific information.

1. Fill in Plant Name/Mix id/strength targets/date
2. List raw materials and suppliers at the bottom of the table and also list in "Material" column of the table.
3. List material specific gravities (ask material suppliers) and determine and list aggregate ratios in last table.
4. Add weights of cementitious materials, target admixture dosages, and air content and acceptable range (+/-).
5. Add target slump or spread with +/- and desired water/cement ratio.
6. Check overall batch properties and confirm that they meet State/local requirements as applicable.

*****ELECTRONIC CALCULATOR AVAILBALE ON ACPA MEMBERS ONLY WEBSITE*****

| | | | | | |
|--|----------------------------|--|-------------------------|------------------------------|---------------------|
|  American Concrete Pipe Association | | <h2 style="margin: 0;">Concrete Mix Design Data for</h2> | | | |
| Mix Designation | | Targets (psi) | | Date | |
| | | 1 Day: | | | |
| | | 28 Day: | | | |
| | Material | Cubic Yard Quantity | Specific Gravity | Cubic Yard Volume | |
| Cement | | lbs | | ft ³ | |
| Cementitious Materials | | lbs | | ft ³ | |
| | | lbs | | ft ³ | |
| Aggregates | | lbs | | ft ³ | |
| | | lbs | | ft ³ | |
| | | lbs | | ft ³ | |
| | | lbs | | ft ³ | |
| Chemical Admixtures | | oz/CWT | | oz | |
| | | oz/CWT | | oz | |
| | | oz/CWT | | oz | |
| | | oz/CWT | | oz | |
| | | oz/CWT | | oz | |
| Water | Water | lbs | | ft ³ | |
| Air | Air Content, % | | + - | ft ³ | |
| Batch Properties | SCM, % | | | Total Volume | ft ³ |
| | Total Cementitious | lbs | | Yd³ Weight | lbs/yd ³ |
| | Water Cement Ratio* | | | Unit Weight | lbs/ft ³ |
| | Slump Spread | | in +/- | | in |
| Material | Type/Classification | Supplier | | | |
| | | | | | |
| | | | | | |
| | | | | | |
| | | | | | |
| | | | | | |
| | | | | | |
| | | | | | |

Compensating for Aggregate Moisture

In the batching of concrete, it is important to compensate for moisture present the aggregates that are used. All aggregates naturally hold a certain percentage of water inside of them, called their **absorption**. This water is unavailable to react with the cement in a mix. Aggregate particles that are internally saturated, but dry on the outside are referred to as saturated surface dry (**SSD**).

Scale weights for a batch are seldom aggregate SSD weights, and are usually more or less depending on the actual moisture content of the aggregate. If the aggregate is not internally saturated, extra water shall be added to the batch. If there is excess moisture coming in with the aggregate, we shall take water out of the batch. This excess moisture is called **Free Moisture**, because it reacts in the mix.

The **Total Moisture** of an aggregate can be found by the procedure outlined below, and if the material's absorption is known, the Free Moisture can be calculated from this test as well.

To Calculate % Moisture of Aggregates:

Gather a representative sample of all aggregates as a batch is being weighed up. Record weights and quantities of all ingredients from that same batch, using a copy of the batch printout if available.

Calculate the Total Moisture % using the following steps:

1. Samples shall be stored in a ziploc bag or otherwise air tight container to prevent drying out before weighing.
2. The sample size shall be a minimum of 500 grams
3. Tare the scale so that it reads zero when an empty pan is placed on it, then add the aggregate sample and record weight of "wet" sample to nearest tenth (.1) of a gram.
4. Transfer sample to a different pan and place on a hot plate, making sure to get all the aggregate into the pan.
5. Completely dry the sample on the hot plate. When reweighing the sample, it shall be transferred into the pan on the scale, because the hot pan would damage the scale.
6. The sample is completely dry when successive weights 5 minutes apart agree within one tenth (.1) of a gram. Take care not to lose any of the sample.

Total Moisture is calculated as follows:

$$\frac{\text{wet weight} - \text{dry weight}}{\text{dry weight}} * 100 = \text{Total Moisture of sample dry weight}$$

$$\frac{510.0 - 485.0}{485.0} * 100 = 5.15\% \text{ Total Moisture}$$

% Total Moisture - % absorption = % Free Moisture

Ex: 5.15% Total moisture - 1.45% absorption = **3.70% Free Moisture**

To Confirm the Water/Cement Ratio of a Mix

Determine the Total Amount of water in the mix, including that due to aggregate moisture, by using the aggregate % moistures as calculated above and the amount of mix ingredients from the same batch.

Ex: There is 1478 pounds of an aggregate that has 3.70% Free Moisture, so:

$$\text{Weight of batched aggregate} - \left(\frac{\text{Weight of batch aggregate}}{1 + \left(\% \text{Free} \frac{\text{Moisture}}{100} \right)} \right) = \text{water in aggregate}$$

$$1478 - \left(\frac{1478}{1 + .037} \right) = \text{pounds of water} \rightarrow 1478 - 1425.28 = \mathbf{52.73 \text{ pounds of water}}$$

*This can be a negative number if the Free Moisture % is less than zero

This calculation shall be done for all aggregate types in the mix. Other metered water or temper water added shall be converted to pounds. One gallon of water equals 8.33 pounds.

$$\text{Water/Cement Ratio} = \frac{\text{Total lbs. Water}}{\text{Total lbs. Cementitious}}$$

*Total cementitious includes Slag and Fly Ash if used in the mix.

Gasketed Pipe & Manhole Joint Data Form

| Pipe Dia. | Joint Type | Dimensions | | | | | | | | | | | | | | | | |
|-----------|------------|-------------------------|------|------|---|------|------|------|--------------|------|------|--------------|------|------|--|--|--|--|
| | | Gasket Recess Width (W) | | | R | d | | | M (Diameter) | | | N (Diameter) | | | | | | |
| | | Nom. | Min. | Max. | | Nom. | Min. | Max. | Nom. | Min. | Max. | Nom. | Min. | Max. | | | | |
| | | | | | | | | | | | | | | | | | | |

| Slope Degrees | | | | | Rubber Gasket | | | Single Offset Gasket Width (GW) | Stretched Height of Single Offset Gasket (H) | F | L | T | X | A | B | K |
|----------------|----------------|----------------|----------------|----------------|--------------------------|---------------|-----------|---------------------------------|--|---|---|---|---|---|---|---|
| S ₁ | S ₂ | S ₃ | S ₄ | S ₅ | Unstretched Diameter (D) | % Stretch (S) | Durometer | | | | | | | | | |
| | | | | | Nom. | Design | Nom. | Nom. | Nom. | | | | | | | |

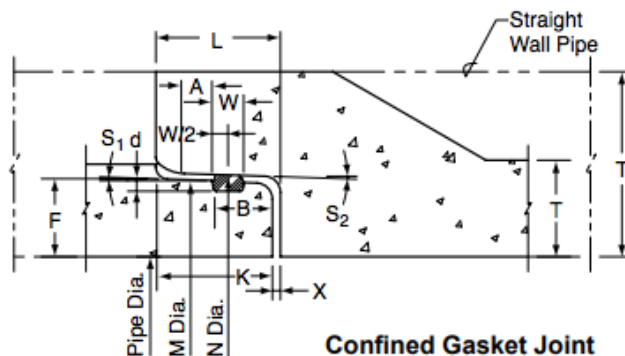
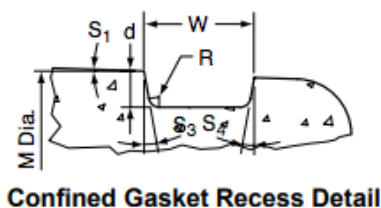
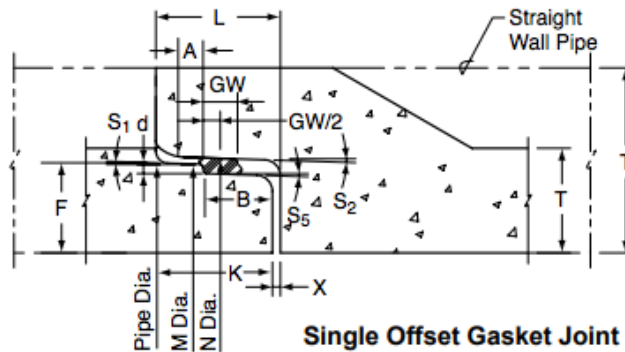
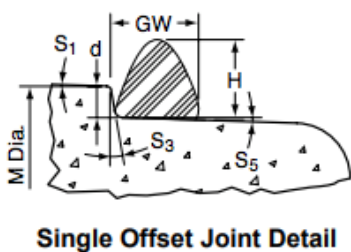

Notes:

Supplier shall submit all information required by the above tables, unless a dimension shown in the tables is not applicable to the specific type of pipe joint furnished, in which case it shall be left blank. All dimensions shall be given in inches, unless otherwise noted.

| | |
|--|-------|
| American Concrete Pipe Association Adopted from the United States Department of the Interior Bureau of Reclamation | |
| Joint Data Form | |
| Pipe Manufacturer | _____ |
| Specification No | _____ |
| Date | _____ |
| Manufacturing Dwg No | _____ |

Non Gasketed Pipe, Manhole, Box Culvert and Three-Sided Structures Joint Data Form

Dimensions

| Box Size Range | | Tongue Length | | | Tongue 1 | | | Tongue 2 | | | Joint Corner Radius | | | |
|----------------|------|---------------|------|------|----------|------|------|----------|------|------|---------------------|----------------|----------------|----------------|
| Span | Rise | Nom. | Min. | Max. | Nom. | Min. | Max. | Nom. | Min. | Max. | R ₁ | R ₂ | R ₃ | R ₄ |
| N/A | N/A | | | | | | | | | | | | | |

| Slope | | Groove Length | | | Groove 1 | | | Groove 2 | | | Annular Space | | |
|----------------|----------------|---------------|------|------|----------|------|------|----------|------|------|---------------|------|------|
| S ₁ | S ₂ | Nom. | Min. | Max. | Nom. | Min. | Max. | Nom. | Min. | Max. | Nom. | Min. | Max. |
| | | | | | | | | | | | | | |

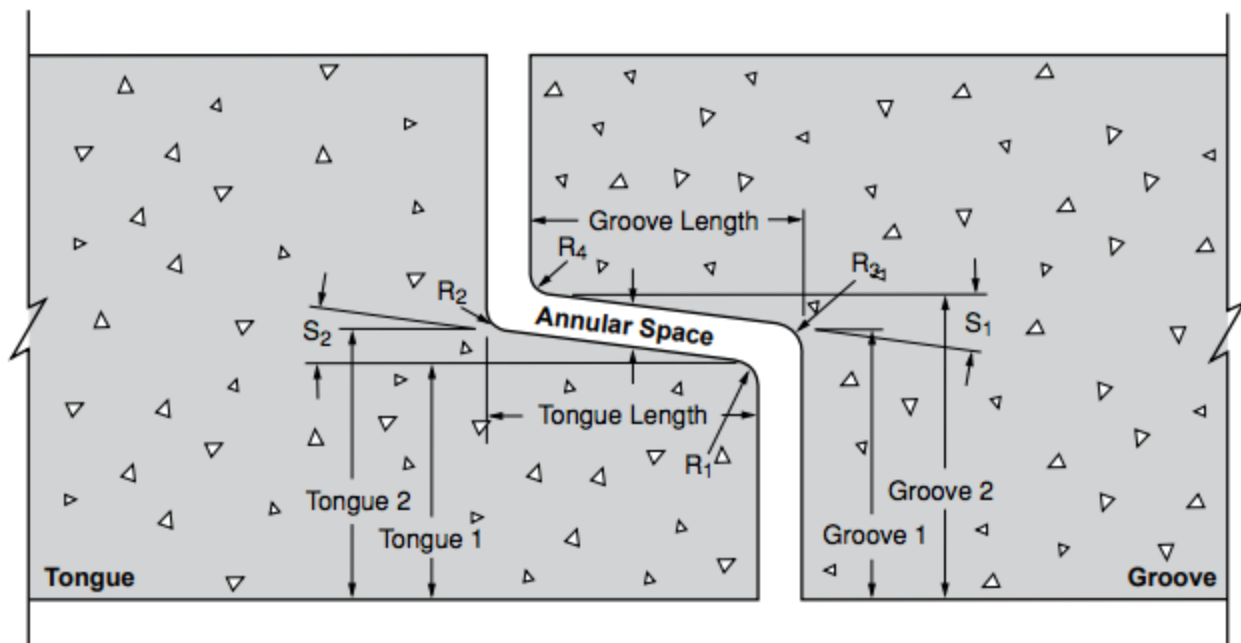

Notes:
 Supplier shall submit all information required by the above tables, unless a dimension shown in the tables is not applicable to the specific type of pipe joint furnished, in which case it shall be left blank. All dimensions shall be given in inches, unless otherwise noted.

| Joint Information |
|-------------------------|
| Manufacturer _____ |
| Joint Designation _____ |
| Date _____ |

Single Offset Box Culvert Joint Data Form

Dimensions

| Box Size Range | | Tongue Length | | | Tongue 1 | | | Tongue 2 | | | Joint Corner Radius | | | |
|----------------|------|---------------|------|------|----------|------|------|----------|------|------|---------------------|----------------|----------------|----------------|
| Span | Rise | Nom. | Min. | Max. | Nom. | Min. | Max. | Nom. | Min. | Max. | R ₁ | R ₂ | R ₃ | R ₄ |
| N/A | N/A | | | | | | | | | | | | | |

| Slope | | Groove Length | | | Groove 1 | | | Groove 2 | | | Annular Space | | |
|----------------|----------------|---------------|------|------|----------|------|------|----------|------|------|---------------|------|------|
| S ₁ | S ₂ | Nom. | Min. | Max. | Nom. | Min. | Max. | Nom. | Min. | Max. | Nom. | Min. | Max. |
| | | | | | | | | | | | | | |

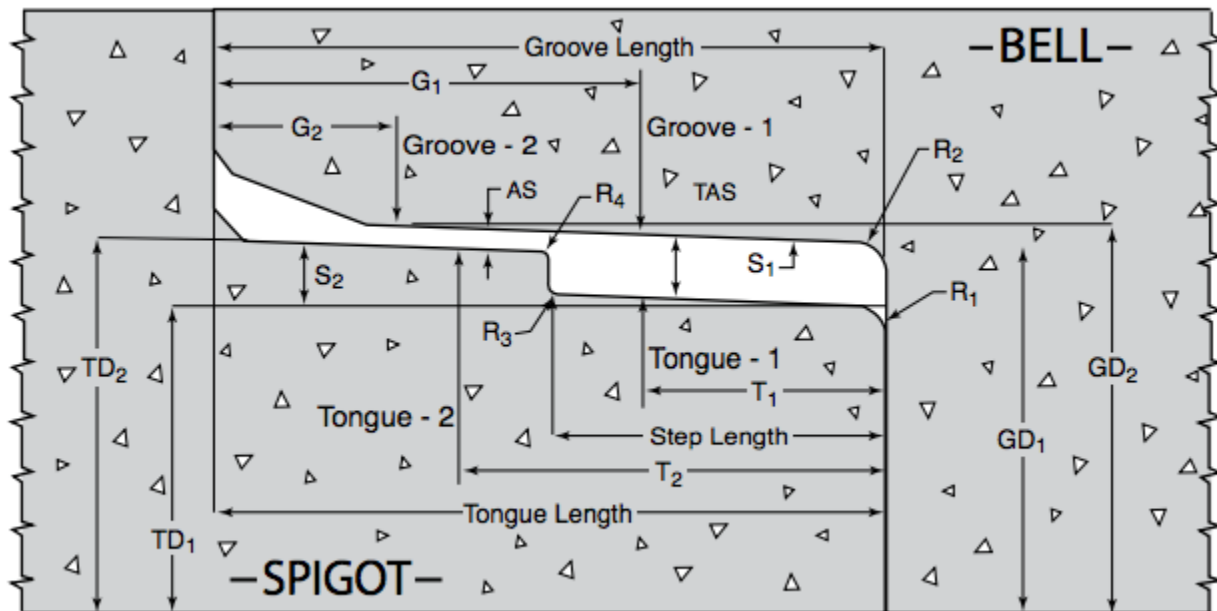

| JOINT INFORMATION | |
|-------------------|-------|
| Manufacturer | _____ |
| Joint Designation | _____ |
| Date | _____ |

Joint Design - Sanitary Sewer Pipe Only

Adequate gasket compression is critical to concrete pipe joint performance. The following discussion describes the requirements and rationale to be used in calculating gasket compression.

NOTATION - See Drawing Appendix A, included in this form.

Annular Space – The distance between the spigot and bell when the completed joint is on a centered position.

DGP- Design gasket pack.

d- Design depth of gasket recess.

Design dimensions- Theoretical joint dimensions.

DGRA- Design gasket recess area.

DGRV- Design gasket recess volume.

DGV- Design gasket volume.

DSGA- Design stretched gasket area of a circular gasket.

DSGD- Design stretched gasket diameter of a circular gasket.

Ellipticity- Difference in maximum or minimum diameters and the design diameter of the joint or the joint forming equipment.

GW- Width of single offset gasket.

M- Design joint diameter at base of the gasket recess.

MnGC- Minimum gasket compression.

MxGC- Maximum gasket compression.

N- Design joint diameter of the groove at center of gasket contact area.

Nominal dimensions- Theoretical joint dimensions, used in the same context as design dimensions.

Profile Gasket- Gasket with non-circular cross section.

Single Offset Joint- Joint with gasket positioned in a notch shaped recess at the end of the spigot and seated against the inside of the bell.

S- Stretch in gasket in the installed position, in percent.

S1- Slope of spigot sealing surface, in degrees.

S2- Slope of bell sealing surface, in degrees.

S3 and S4- Side slopes of gasket recess, in degrees.

S5- Slope of single offset sealing surface, in degrees.

Sealing Surface- Surfaces of the spigot and groove that compress the gasket as the joint is made.

SPGH- Stretched profile gasket height.

Tolerance- The difference in the actual joint dimensions and the design dimensions.

UGD- Unstretched gasket diameter of circular gasket.

W- Width of gasket recess.

GASKET STRETCH AND COMPRESSION REQUIREMENTS

For circular gaskets installed in a gasket recess with the design gasket volume less than 75% of gasket recess volume:

- 20% maximum gasket stretch, S
- 15% minimum gasket compression, MnGC,
- 40% maximum gasket compression, MxGC.

With nominal gasket volume 75% or greater of gasket recess volume:

- 30% maximum gasket stretch, S
- 15% minimum gasket compression,
- 50% maximum gasket compression.

For non-circular gaskets installed in a gasket recess or on an offset in a joint surface:

- 15% minimum gasket compression,
- 60% maximum gasket compression.

GASKET COMPRESSION DEFINITIONS and FORMULAS

Diameter of Stretched Circular Gaskets

For gasket compression calculations, the design stretched gasket diameter, DSGD, shall be calculated by dividing the unstretched gasket diameter, UGD, by the square root of the sum of one plus the design percentage of stretch, S, divided by 100.

Design stretched gasket diameter is calculated by the formula:

$$DSGD = \frac{UGD}{\sqrt{(1 + S/100)}}$$

Design Gasket Pack

When evaluating gasket compression limits for confined circular gaskets, the design gasket volume, DGV, is compared to the design gasket recess volume, DGRV. This comparison is called the design gasket pack, DGP. The gasket recess volume is calculated using design values with the spigot located concentrically within the groove. Because the length of the stretched gasket and the gasket recess of the joint is identical, only the design stretched gasket area, DSGA, and designed gasket recess area, DGRA, need be compared for this calculation.

$$DGP = \frac{DSGA}{DGRA} \times 100\%$$

Design stretched gasket cross sectional area, DGSA, is calculated by the formula:

$$DSGA = \left(\frac{\pi}{4}\right) \times (DSGD)^2$$

The design gasket recess area, DGRA, is calculated by taking the design recess depth, d , at the midpoint of the gasket recess plus the design annular space times the recess width, W . Design gasket recess area is calculated using nomenclature found on the Joint Data Form illustration and the following formula:

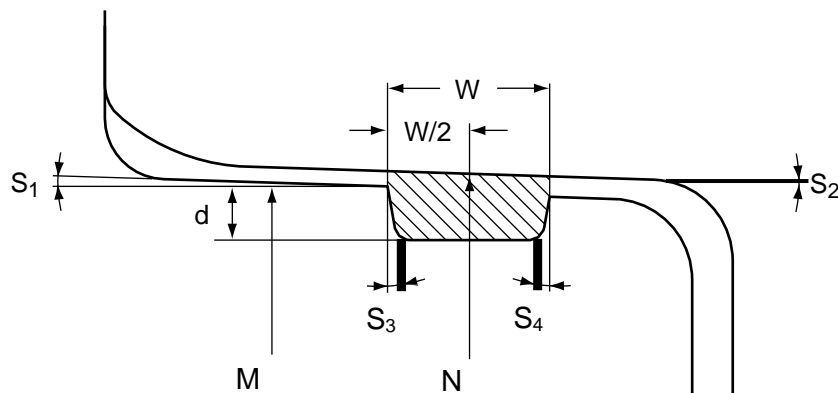

Design Gasket Recess Area

$$DGRA^* = \left[\frac{N}{2} - \left(\frac{M}{2} - d \right) \right] W - \left(\frac{d^2 \tan S_3}{2} + \frac{(d - W \tan S_1)^2 \tan S_4}{2} \right)$$

*To simplify this calculation, the area outside the radii at the base of the gasket recess is not excluded from the gasket recess area.

Maximum Gasket Compression

Maximum gasket compression, $MxGC$, occurs at a point where the outer surface of the spigot contacts the inner surface of the bell. The nominal depth of the gasket recess, d , shall be reduced by the tolerance for manufacturing and positioning the gasket recess formers or the shape and position of a ground recess. Maximum gasket compression shall be determined at the center of the gasket recess or for a single offset joint, the center of the gasket.

Maximum gasket compression, in percent, can be calculated using the following formulas:

Confined Circular Gasket Joint:

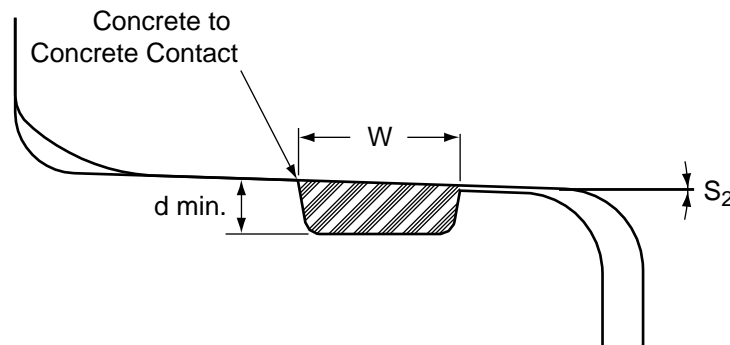

Maximum Gasket Compression in a Confined Gasket Joint

$$MxGC = \left(1 - \frac{d \text{ min} - \frac{1}{2} W \tan S_2}{DSGD} \right) \times 100\%$$

Single Offset Gasket Joint:

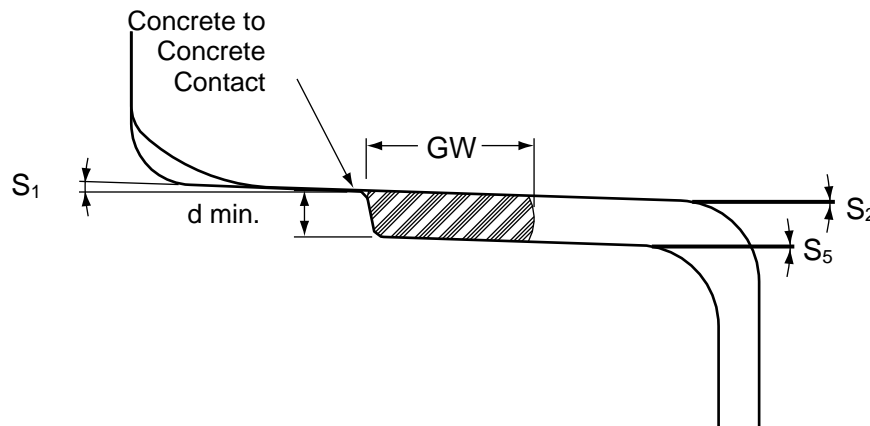

Maximum Gasket Compression in a Single Offset Gasket Joint

$$MxGC = \left[1 - \frac{d_{min} - \frac{1}{2}GW \tan(S_2) + \frac{1}{2}GW \tan(S_5)}{SPGH} \right] \times 100 \quad MxGC_{parallel} = \left[1 - \frac{D_{min}}{SPGH} \right] 100$$

Minimum Gasket Compression

Minimum gasket compression, MnGC, is determined when the maximum dimension of the inside surface of the bell, and minimum dimension of the gasket recess occur at the same location that is opposite a point where the bell and spigot are in contact. The maximum bell dimension shall be calculated by adding the tolerance in fabricating joint formers, and the added variability caused by repeated use of the formers, to the nominal inside diameter of the bell. The minimum of the base of the gasket recess shall be calculated by subtracting the tolerance in fabricating the joint formers and gasket recess formers, the negative value of added variability caused by repeated use of the formers, and the maximum depth of the gasket recess from the nominal spigot dimension.

Minimum gasket compression, MnGC, in percent, can be calculated using the following formulas:

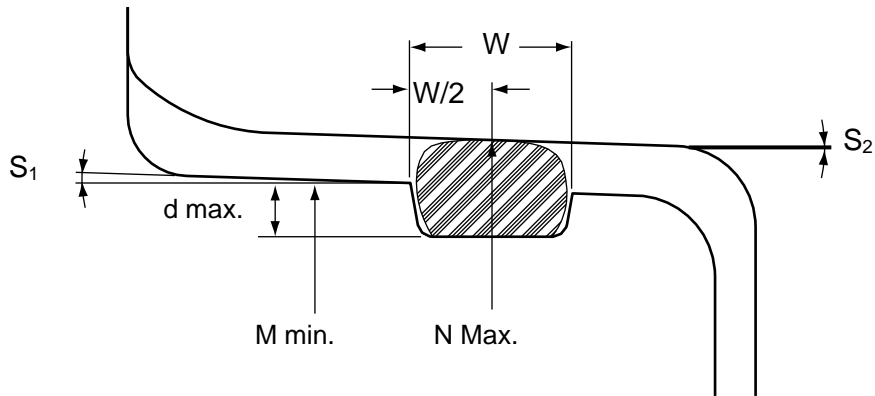

Minimum Gasket Compression in a Confined Gasket Joint

$$MnGC \left[1 - \left(\frac{N_{max} - [M_{min} - 2(1/2 w \tan S_1)] + (d_{max} - 1/2 W \tan S_1)}{DSGD} \right) \right] \times 100\%$$

Confined Offset Gasket Joint:

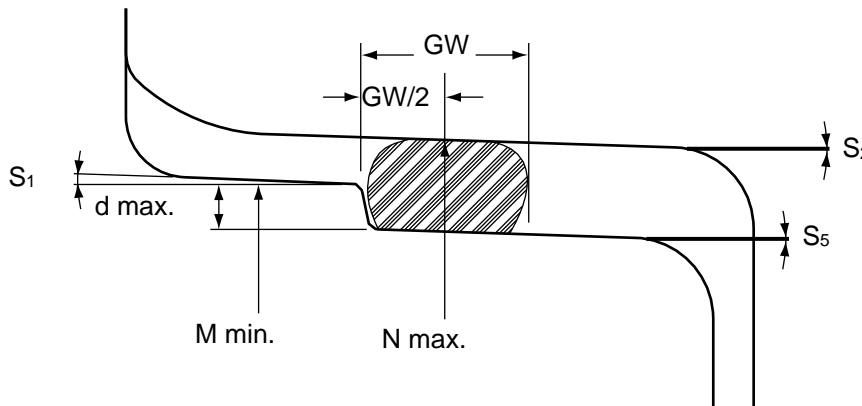

Minimum Gasket Compression in a Single Offset Gasket Joint

$$MnGC = \left[1 - \frac{N_{max} - (M_{min} - 1/2 GW \tan(S_2)) + D_{max} + 1/2 GW \tan(S_5)}{SPGH} \right] 100$$

$$MnGC_{Parallel} = \left[1 - \frac{N_{max} - M_{min} + D_{max} + GW \tan(S_{2,5})}{SPGH} \right] 100$$

Spigot Go/No-Go Gauge - Sanitary Sewer Pipe Only

| Size | Mark | L1 Go | L2 No-Go | L3 | L4 | L5 | L6 | L7 | L8 | L9 |
|------|--------------------|-------|----------|----|----|----|----|----|----|----|
| 12" | 12" Gasket Recess | | | | | | | | | |
| 15" | 15" Gasket Recess | | | | | | | | | |
| 18" | 18" Gasket Recess | | | | | | | | | |
| 21" | 21" Gasket Recess | | | | | | | | | |
| 24" | 24" Gasket Recess | | | | | | | | | |
| 27" | 27" Gasket Recess | | | | | | | | | |
| 30" | 30" Gasket Recess | | | | | | | | | |
| 33" | 33" Gasket Recess | | | | | | | | | |
| 36" | 36" Gasket Recess | | | | | | | | | |
| 42" | 42" Gasket Recess | | | | | | | | | |
| 48" | 48" Gasket Recess | | | | | | | | | |
| 54" | 54" Gasket Recess | | | | | | | | | |
| 60" | 60" Gasket Recess | | | | | | | | | |
| 66" | 66" Gasket Recess | | | | | | | | | |
| 72" | 72" Gasket Recess | | | | | | | | | |
| 78" | 78" Gasket Recess | | | | | | | | | |
| 84" | 84" Gasket Recess | | | | | | | | | |
| 90" | 90" Gasket Recess | | | | | | | | | |
| 96" | 96" Gasket Recess | | | | | | | | | |
| 108" | 108" Gasket Recess | | | | | | | | | |

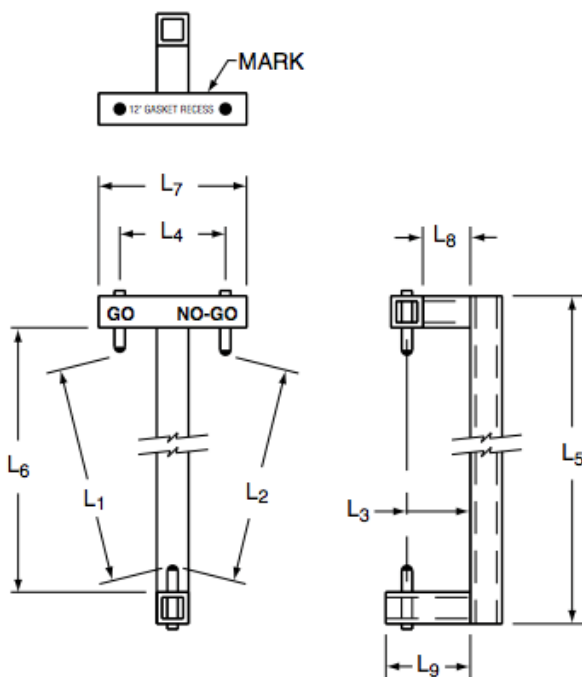

Suggested Construction:

1. Use 3/4" x 11 gauge sq. steel tubing
2. Use 1/4" steel drill rod for points. Grind and file to about 1/8" points.
3. Stamp "GO", "NO-GO" and Description on gauge before finish dimensioning.

TITLE
 GO/NO-GO GAUGE & DIMENSIONS FOR O-RING GASKET RECESS

Signature: _____

Date: _____

Gasket Testing Procedures (ASTM C497)

~~Inspection reports shall be filled out for each sample inspected in production processes. A gasket report shall be filled out for each gasket inspected.~~ The report shall include all required dimensions and the manufacturers printing on gaskets. ~~A~~ Reference sheets or inspection sheets showing allowable gasket tolerances shall also be available to compare to test results.

Height and Width of Pre-lubricated and Profile Gaskets

a. Gasket manufacturer producing gaskets from gasket cord

Measure the height and width on either side of gasket splice staying outside the area affected by the splice die. Record the average of both dimensions.

b. Gasket manufacturer producing gaskets from rubber compound

Measure the height and width on samples collected during production run using proper measuring tools at defined frequency.

Cord Diameter – Circular Cross-sections

a. Gasket manufacturer producing gaskets from gasket cord

Measure the cord diameter at 0° and 90° on both sides of the gasket splice taking care to measure beyond the area affected by the splice die. The cord diameter is an average of these four readings.

b. Gasket manufacturer producing gaskets from rubber compound

Measure the cord diameter at 0° and 90° on samples collected during production run using proper measuring tools at defined frequency. The cord diameter is an average of these two (2) readings.

Gasket Length

Cut length can be measured directly by the manufacturer prior to splicing or completed gasket can be cut. Testing can be done on completed gaskets by not cutting the gasket using the following procedure. Construct a flat, straight calibrated measuring scale such as a measuring tape attached to a table or the floor. Make an index mark on the gasket cross-section. Place the gasket index mark at the zero point of the measuring scale and carefully roll the uncut gasket loop along the measuring scale without slipping or stretching. The gasket length is the distance measured at the point where the index mark retouches the scale.

Gasket Durometera. Gasket manufacturer producing gaskets from gasket cord

Measure gasket material hardness using a durometer according to ASTM D 2240. Measure hardness on both sides of the splice staying outside the area affected by the splice die. The hardness is the average of these two readings.

a. Gasket manufacturer producing gaskets from rubber compound

Measure gasket material hardness on samples collected during production run using a durometer at defined frequency.

Splice Strength

Place two index marks 2 inches apart, 1" either side of gasket splice. Apply an axial force until the marks are 4" apart. While stretched, the gasket shall be visually inspected for tears, cracks or separation. Alternatively, use calibrated splice testing equipment that provides at least 100 percent elongation of the test area.

Gasket Volume (non pre-lubricated)

Determine the weight of the gasket in grams by weighing it on a gram scale to the nearest gram. Next determine the weight of same gasket by weighing it totally immersed in water. A surfactant shall be added to the water to thoroughly wet the gasket surface and prevent air bubbles from clinging to the gasket. The difference in the dry weight and the immersed weight, measured in grams, is the volume of the gasket in cubic centimeters.

As an alternate to the above, Alternate procedure: †The gasket may be placed in a water tank and the volume of water displaced recorded. The displaced volume of water may be measured directly in cubic centimeters by pouring into a calibrated tube, or it may be weighed. One gram of water equals one cubic centimeter.

Alternate procedure: Measure O-ring gasket specific gravity (minimum one per reel or shipment). Measure dry weight (grams) of O-Ring gasket. Divide weight (grams) by tested specific gravity for gasket volume.

Confined Gasket Header Inspection Report

Incoming Inspection No. _____

Vendor _____ Item _____ Header-Confined Gasket _____

Order No. _____ Qty. Order _____ Qty. Inspected _____

Date Received _____ Date Inspected _____

Drawing No's. _____

| Ring No. | | | | | 1 | 2 | 3 | 4 | | |
|-------------------------|-------------|------|----------------|--|---|---|---|---|--|--|
| | | | Specifications | | | | | | | |
| Header ID | | | | | | | | | | |
| Header OD | | | | | | | | | | |
| Top Flange Thickness | | | | | | | | | | |
| Bottom Flange Thickness | | | | | | | | | | |
| Spigot Height | | | | | | | | | | |
| Snap Ring Height | | | | | | | | | | |
| Snap Ring Width | | | | | | | | | | |
| Snap Ring Thickness | | | | | | | | | | |
| Slope ID* | | 0° | | | | | | | | |
| | | 45° | | | | | | | | |
| | | 90° | | | | | | | | |
| | | 135° | | | | | | | | |
| | | Ave. | | | | | | | | |
| | Ellipticity | | | | | | | | | |
| | | | | | | | | | | |
| | | | | | | | | | | |

* Slope ID is used for both the incoming inspection and annual inspection for sanitary sewer certification. For the annual inspection for sanitary sewer, measuring the actual minimum and maximum slope is sufficient.

Page _____ Cont. on Page _____

Signed _____

Header Inspection Drawing

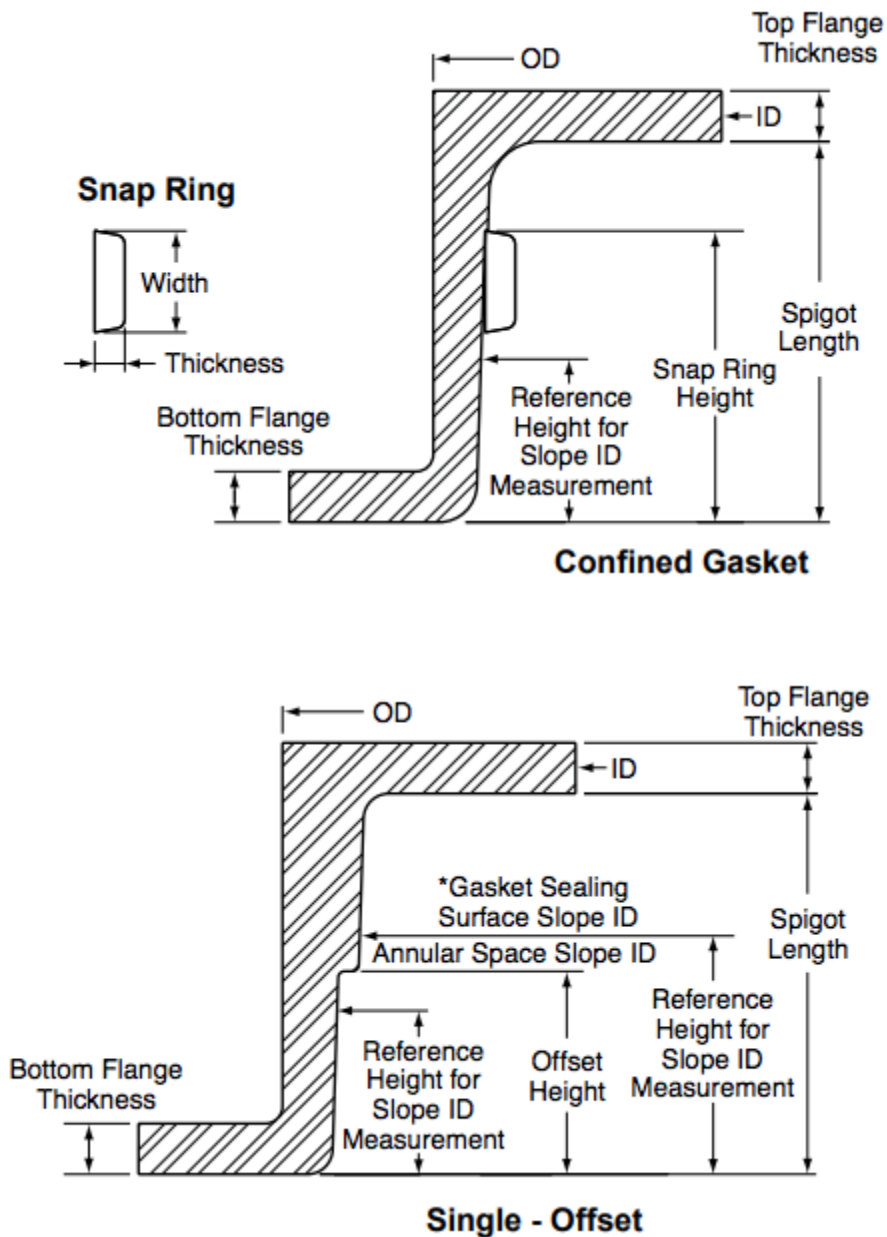

Incoming inspection shall include all inspection locations.

*Annual inspections for Sanitary Sewer Tested Pipe and Sanitary Sewer Manhole certification need only include slope ID inspection for confined gasket header or gasket sealing surface slope ID for single offset header.

Pallet Inspection Report

Incoming Inspection No. _____

Vendor _____ Item _____ Pallet _____

Order No. _____ Qty. Order _____ Qty. Inspected _____

Date Received _____ Date Inspected _____

Drawing No's. _____

| Ring No. | | | | | | 1 | 2 | 3 | 4 | | |
|-------------------------|-------------|------|----------------|--|--|---|---|---|---|--|--|
| | | | Specifications | | | | | | | | |
| Pallet ID | | | | | | | | | | | |
| Pallet OD | | | | | | | | | | | |
| Top Flange Thickness | | | | | | | | | | | |
| Bottom Flange Thickness | | | | | | | | | | | |
| Pallet Height | | | | | | | | | | | |
| Leg Location | | | | | | | | | | | |
| Slope OD* | | 0° | | | | | | | | | |
| | | 45° | | | | | | | | | |
| | | 90° | | | | | | | | | |
| | | 135° | | | | | | | | | |
| | | Ave. | | | | | | | | | |
| | Ellipticity | | | | | | | | | | |
| | | | | | | | | | | | |
| | | | | | | | | | | | |
| | | | | | | | | | | | |

* Slope ID is used for both the incoming inspection and annual inspection for sanitary sewer certification. For the annual inspection for sanitary sewer, measuring the actual minimum and maximum slope is sufficient.

Page _____ Cont. on Page _____

Signed _____

Pallet Inspection Location

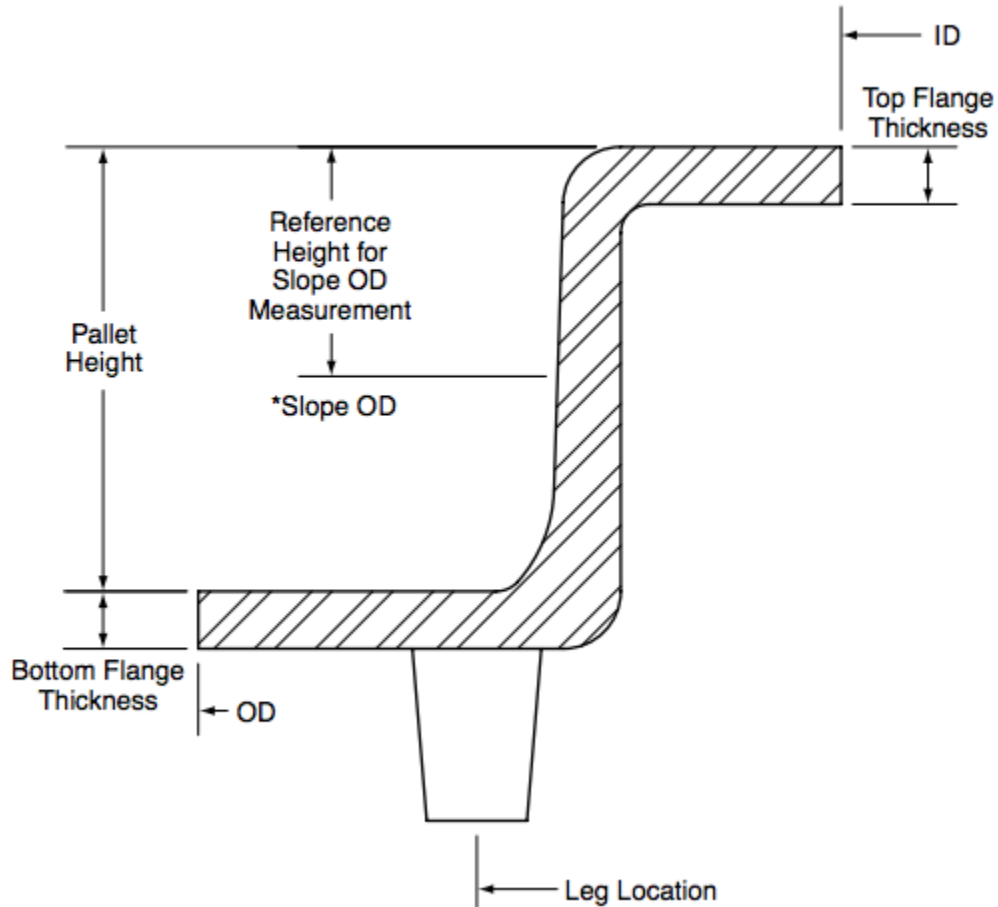

Incoming inspection shall include all inspection locations.

* Annual inspections for Sanitary Sewer Pipe and Sanitary Sewer Manhole certification need only include slope OD inspection.

Truing Ring Inspection Report

Incoming Inspection No. _____

Vendor _____ Item _____ Outside Truing Ring _____

Order No. _____ Qty. Order _____ Qty. Inspected _____

Date Received _____ Date Inspected _____

Drawing No's. _____

| Ring No. | | | | | 1 | 2 | 3 | 4 | | |
|----------------------------------|-------------|----------------|--|--|---|---|---|---|--|--|
| | | Specifications | | | | | | | | |
| Truing Ring Height | | | | | | | | | | |
| Offset Height | | | | | | | | | | |
| Gasket Sealing Surface Slope ID* | 0° | | | | | | | | | |
| | 45° | | | | | | | | | |
| | 90° | | | | | | | | | |
| | 135° | | | | | | | | | |
| | Ave. | | | | | | | | | |
| | Ellipticity | | | | | | | | | |
| Annular Space Slope ID | 0° | | | | | | | | | |
| | 45° | | | | | | | | | |
| | 90° | | | | | | | | | |
| | 135° | | | | | | | | | |
| | Ave. | | | | | | | | | |
| | Ellipticity | | | | | | | | | |
| | | | | | | | | | | |
| | | | | | | | | | | |

* Gasket sealing manhole surface slope ID is used for both sanitary sewer pipe and the incoming inspection and annual inspection for sanitary sewer certification. For the annual inspection for sanitary sewer certification, measuring the actual minimum and maximum slope is sufficient.

Page _____ Cont. on Page _____

Signed _____

Single Offset Box Culvert Pallet and Header Inspection Report (Spigot Down)

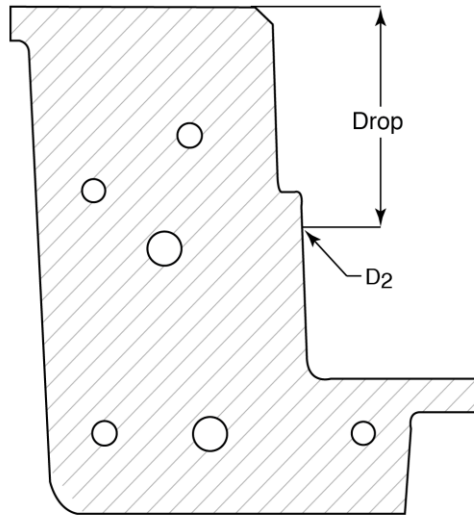

PALLET
TYPICAL CROSS SECTION

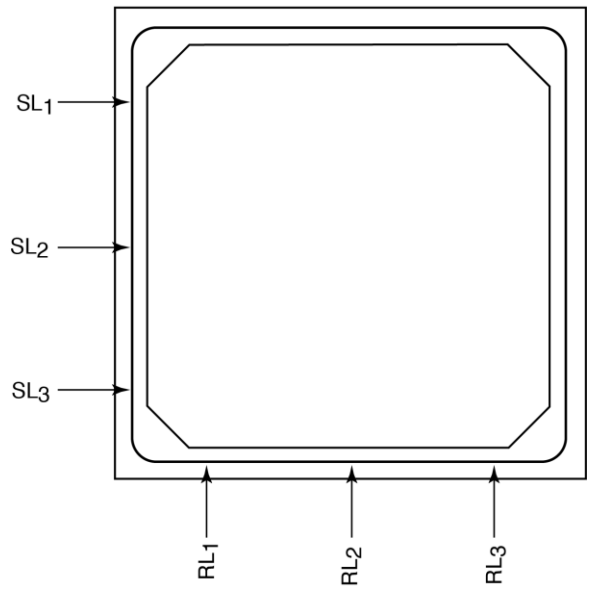

PLAN VIEW OF BOX

Single Offset Box Culvert Pallet and Header Inspection Report (Bell Down)

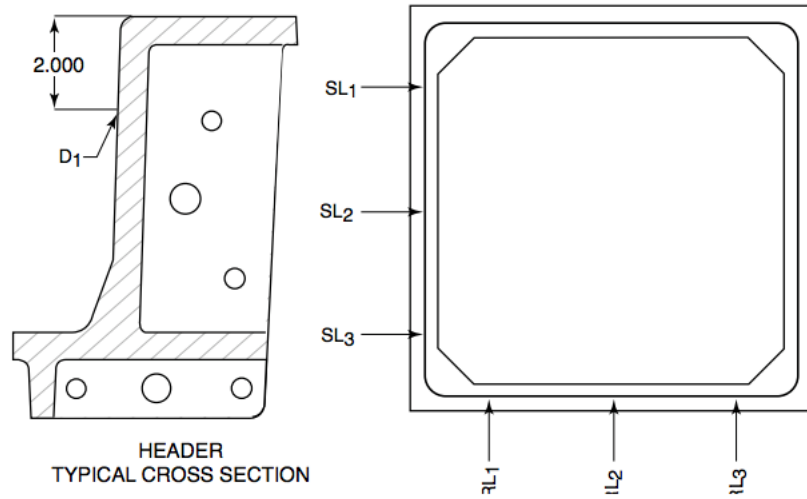

Single Offset Box Culvert Pallet and Header Inspection Report

Incoming Inspection No. _____

Vendor _____ Item _____

Order No. _____ Qty. Order _____ Qty. Inspected _____

Date Received _____ Date Inspected _____

Drawing No's. _____

Span _____ Rise _____ Haunch Size _____

| Ring No. | | | | 1 | 2 | 3 | 4 | | | |
|-------------------------|----------------|--|--|---|---|---|---|--|--|--|
| | Specifications | | | | | | | | | |
| Rise (RL ₁) | | | | | | | | | | |
| Rise (RL ₂) | | | | | | | | | | |
| Rise (RL ₃) | | | | | | | | | | |
| Span (SL ₁) | | | | | | | | | | |
| Span (SL ₂) | | | | | | | | | | |
| Span (SL ₃) | | | | | | | | | | |
| D ₁ | | | | | | | | | | |
| | | | | | | | | | | |
| | | | | | | | | | | |
| | | | | | | | | | | |

Page _____ Cont. on Page _____

Signed _____

Inside Truing Ring Inspection Location

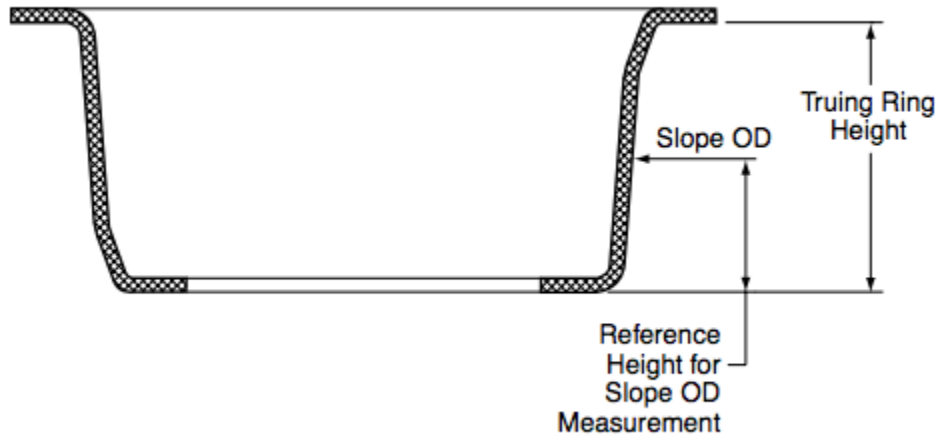

Outside Truing Ring Inspection Location

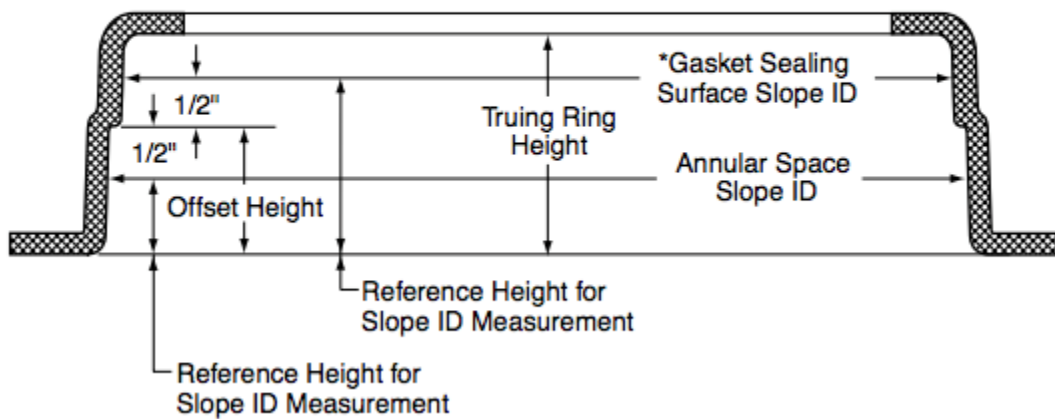

* Annual inspections for sanitary sewer pipe and sanitary sewer manhole certification need only to include gasket sealing surface slope ID inspection.

Pipe Reinforcing Inspection Worksheet

Guideline: Document one cage at start of each shift and if any settings are changed.
Minimum required measurements shown.

| | | | | | | | | |
|------------------------------|-------|-------|-------|-------|-------|-------|-------|-------|
| Date | | | | | | | | |
| Pipe Size | | | | | | | | |
| Pipe Class | | | | | | | | |
| Pipe Wall | | | | | | | | |
| | Meas. | Spec. | Meas. | Spec. | Meas. | Spec. | Meas. | Spec. |
| Dia. - 0° | | | | | | | | |
| Dia. - 90° | | | | | | | | |
| Horiz. Wire Spacing | | | | | | | | |
| Horiz. Wire Dia. | | | | | | | | |
| Area Check | | | | | | | | |
| Vert. Wire Spacing | | | | | | | | |
| Vert. Wire Dia. | | | | | | | | |
| Area Check | | | | | | | | |
| Length | | | | | | | | |
| Lap | | | | | | | | |
| *Bell Dia. - 0° | | | | | | | | |
| *Bell Dia. - 90° | | | | | | | | |
| Weld Check | | | | | | | | |
| Spacer Check size & location | | | | | | | | |

Comments and Corrective Action: _____

Signature: _____

Manhole & Precast Reinforcing Inspection Worksheet

Guideline: Document one cage at start of each shift and if any settings are changed. Minimum required measurements shown, if applicable.

| | | | | | | | | | |
|-------------------------------------|-------|---------------|-----|-------|---------------|-----|-------|---------------|-----|
| Date | | | | | | | | | |
| Product Description, Section Detail | | | | | | | | | |
| Style & Dimension | | | | | | | | | |
| | Meas. | Specified Min | Max | Meas. | Specified Min | Max | Meas. | Specified Min | Max |
| Dia. - 0° | | | | | | | | | |
| Dia. - 90° | | | | | | | | | |
| Horiz. Steel Spacing | | | | | | | | | |
| Horiz. Steel Dia. | | | | | | | | | |
| Area Check | | | - | | | - | | | - |
| Vert. Steel Spacing | | | | | | | | | |
| Vert. Steel Dia. | | | | | | | | | |
| Area Check | | | - | | | - | | | - |
| Length | | | | | | | | | |
| Lap | | | - | | | - | | | - |
| *Bell Dia. - 0° | | | | | | | | | |
| *Bell Dia. - 90° | | | | | | | | | |
| Weld Check | | | | | | | | | |
| Blockout Reinforcement | | | | | | | | | |
| Spacer Check size & location | | | | | | | | | |

Comments and Corrective Action:

Signature: _____

Box Culvert Reinforcement Inspection - Single Cell

| Identification | |
|-------------------|--|
| Fabrication Date | |
| Span/Rise/Length | |
| Wall/Haunch | |
| Design, Table # | |
| Earth Cover, Min. | |
| Earth Cover, Max. | |

Date & Time: _____
 QC Inspector: _____
 Plant: _____
 Project: _____
 Comments: _____

| Reinforcing Areas, in ² /ft. | | | | | | | | |
|---|-----|-----|-----|-----|-----|-----|-----|-----|
| | As1 | As2 | As3 | As4 | As5 | As6 | As7 | As8 |
| Type | | | | | | | | |
| Wire Dia. | | | | | | | | |
| Wire Sp. | | | | | | | | |
| Actual Area/ft. | | | | | | | | |
| Total Area/ft. | | | | | | | | |
| Required Area/ft. | | | | | | | | |

| Reinforcing Cage Dimensions - Span & Rise | | | | | | | | |
|---|-----------|----------|--------|---------|---------|-----------|--------|------------|
| | Cage Type | Location | Design | Minimum | Maximum | Left Side | Middle | Right Side |
| Span | Inner | Top | | | | | | |
| | | Bottom | | | | | | |
| | Outer | Top | | | | | | |
| | | Bottom | | | | | | |
| Rise | Inner | Top | | | | | | |
| | | Bottom | | | | | | |
| | Outer | Top | | | | | | |
| | | Bottom | | | | | | |

| Reinforcing Cage Dimension - Height, Overhangs, Laps | | | | | | | | |
|--|--------|---------|---------|-----|-------|--------|------|--|
| Cage Type | Design | Minimum | Maximum | Top | Right | Bottom | Left | |
| Inner | | | | | | | | |
| Outer | | | | | | | | |
| Overhang | | | | | | | | |
| Cage Lap | | | | | | | | |
| As1 "M" Dimension | | | | | | | | |

| Reinforcing Cage - Misc. | | | | | | | |
|--------------------------|-----------|------------|------------|--|-----------------------|--|-------|
| Spacers | Type/Size | Design Qty | Actual Qty | | Welding Zones | | Check |
| Top | | | | | As2 Middle 1/3 | | |
| Right | | | | | As3 Middle 1/3 | | |
| Bottom | | | | | Outside Corners | | |
| Left | | | | | Weld Quality | | |
| Chairs | | | | | | | |
| Bolsters | | | | | Lifting Holes/Anchors | | |

Box Culvert Reinforcement Inspection Cont.

Place a check mark in the box under OK if requirement is met, or a check mark under HOLD if requirement is not met.

| End Cover | | | |
|------------------------------|----|------|---------|
| Item | OK | Hold | Remarks |
| Circumferential ₁ | | | |
| Longitudinal ₂ | | | |
| Multiple Layer | | | |
| Item | OK | Hold | Remarks |
| Separation ₃ | | | |
| Weld Placement ₄ | | | |
| Laps | | | |
| Item | OK | Hold | Remarks |
| Min. Lap ₅ | | | |
| Weld Placement ₆ | | | |
| Critical Welding Zones | | | |
| Item | OK | Hold | Remarks |
| As2 Mid 1/3 ₇ | | | |
| As3 Mid 1/3 ₇ | | | |
| Distribution Steel | | | |
| Item | OK | Hold | Remarks |
| Weld Placemetn ₈ | | | |
| Spacers | | | |
| Item | OK | Hold | Remarks |
| Location ₉ | | | |
| Size ₁₀ | | | |

1. Not less than 1/2 inch or greater than 2 inches from the end of the box section
2. Not greater than 2 inches from the end of the box section
3. Not greater than one longitudinal thickness plus 1/4 inch
4. If not tied, welds shall be made to selected circumferential wire not less than 18 inches apart
5. One longitudinal spacing plus 2 inches or 10 inches, whichever is greater
6. If not tied, welds shall be made to selected circumferential wire not less than 18 inches apart (at corners of As1, As7 & As8, see Fig. 9 of C1577 & C1433 "Critical Zones of High Stress Where Welding is Restricted")
7. No welding permitted due to high stress (see Fig. 9 in C1577 & C1433 "Critical Zones of High Stress Where Welding is Restricted")
8. Welds shall only be made to longitudinal wires, and only within 18" from the end of the box section
9. Verify that spacers are in the correct location on the cage per manufacturer's drawings
10. Verify against manufacturer's drawings that the correct size of spacer(s) are used

Box Culvert Reinforcement Inspection - Double Cell

| Identification | |
|-------------------|--|
| Fabrication Date | |
| Span | |
| Rise | |
| Design, Table # | |
| Earth Cover, Min. | |
| Earth Cover, Max. | |

Date: _____

Inspector: _____

Comments: _____

| Circumferential and Longitudinal Reinforcing Areas, in ² /ft. | | | | | |
|--|----------|------|------------|------------|--------|
| Mark | Required | Used | Mesh Style | Length "L" | "M"*** |
| As1 | | | | | |
| As2 | | | | | N/A |
| As3 | | | | | N/A |
| As4 | | | | | N/A |
| As5 | | | | | N/A |
| As6 | | | | | N/A |
| As7 | | | | | N/A |
| As8 | | | | | N/A |
| As9 | | | | | N/A |
| As10 | | | | | N/A |
| Inserts | | | N/A | N/A | N/A |
| Spacers | | | N/A | N/A | N/A |
| *Lap | | | N/A | N/A | N/A |

*Where reinforcing cages are overlapped, lap splices for WWR must equal 1 longitudinal wire spacing plus 2 in. and greater than or equal to 10 in.

**M only applies as a design option for boxes with a fill height of 2 ft. and great.

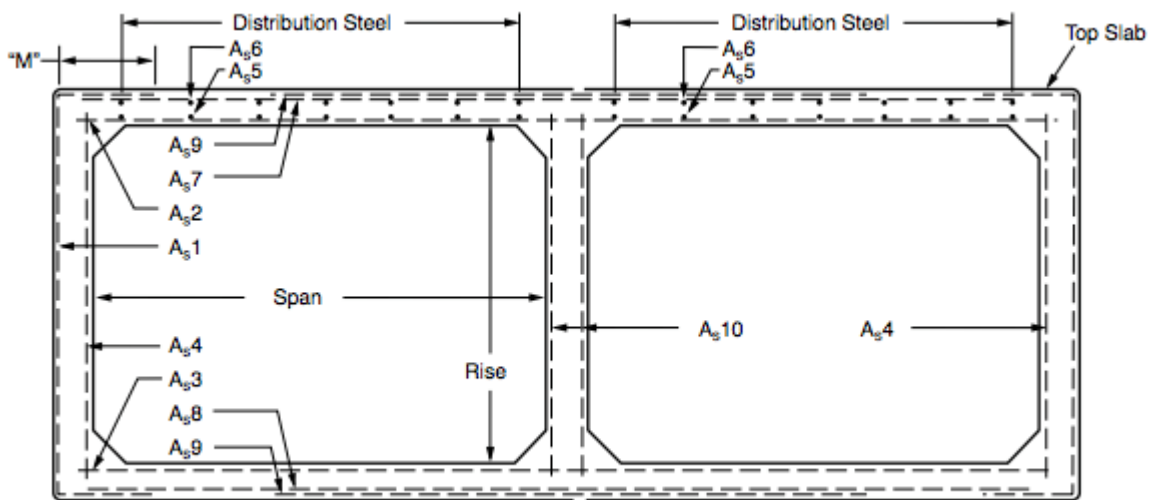

Reinforcing Placement

Box Culvert Reinforcement Inspection Cont.

Place a check mark in the box under OK if requirement is met, or a check mark under HOLD if requirement is not met.

| End Cover | | | |
|------------------------------|----|------|---------|
| Item | OK | Hold | Remarks |
| Circumferential ₁ | | | |
| Longitudinal ₂ | | | |
| Multiple Layer | | | |
| Item | OK | Hold | Remarks |
| Separation ₃ | | | |
| Weld Placement ₄ | | | |
| Laps | | | |
| Item | OK | Hold | Remarks |
| Min. Lap ₅ | | | |
| Weld Placement ₆ | | | |
| Critical Welding Zones | | | |
| Item | OK | Hold | Remarks |
| As2 Mid 1/3 ₇ | | | |
| As3 Mid 1/3 ₇ | | | |
| Distribution Steel | | | |
| Item | OK | Hold | Remarks |
| Weld Placemetn ₈ | | | |
| Spacers | | | |
| Item | OK | Hold | Remarks |
| Location ₉ | | | |
| Size ₁₀ | | | |

- Not less than 1/2 inch or greater than 2 inches from the end of the box section
- Not greater than 2 inches from the end of the box section
- Not greater than one longitudinal thickness plus 1/4 inch
- If not tied, welds shall be made to selected circumferential wire not less than 18 inches apart
- One longitudinal spacing plus 2 inches or 10 inches, whichever is greater
- If not tied, welds shall be made to selected circumferential wire not less than 18 inches apart (at corners of As1, As7 & As8, see Fig. 9 of C1577 & C1433 "Critical Zones of High Stress Where Welding is Restricted")
- No welding permitted due to high stress (see Fig. 9 in C1577 & C1433 "Critical Zones of High Stress Where Welding is Restricted")
- Welds shall only be made to longitudinal wires, and only within 18" from the end of the box section
- Verify that spacers are in the correct location on the cage per manufacturer's drawings
- Verify against manufacturer's drawings that the correct size of spacer(s) are used

Three-sided Structure - Flat Deck Reinforcement Inspection

| Identification | |
|-------------------|--|
| Date Cast | |
| Span | |
| Rise | |
| Earth Cover, Min. | |
| Earth Cover, Max. | |

Date: _____

Inspector: _____

Comments: _____

| Circumferential Reinforcing Areas, in ² /ft. | | | | |
|---|----------|------|------------|------------|
| Mark | Required | Used | Mesh Style | Length "L" |
| As1 | | | | |
| As2 | | | | |
| As3 | | | | |
| As4 | | | | |
| As5 | | | | |
| As6 | | | | |
| As7 | | | | |
| As8 | | | | |
| Inserts | | | N/A | N/A |
| Spacers | | | N/A | N/A |

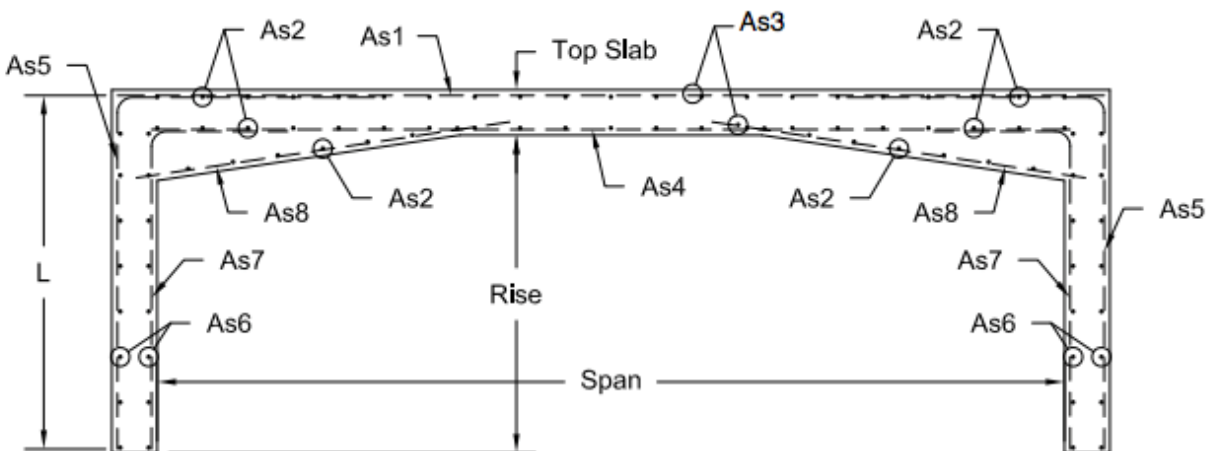

Three-sided Structure - Flat Deck Reinforcement Inspection Cont.

Place a check mark in the box under OK if requirement is met, or a check mark under HOLD if requirement is not met.

| End Cover | | | |
|--------------------------------------|----|------|---------|
| Item | OK | Hold | Remarks |
| Circumferential ₁ | | | |
| Longitudinal ₂ | | | |
| Multiple Layer | | | |
| Item | OK | Hold | Remarks |
| Separation ₃ | | | |
| Weld Placement ₄ | | | |
| Laps | | | |
| Item | OK | Hold | Remarks |
| Min. Lap ₅ | | | |
| Weld Placement ₆ | | | |
| Critical Welding Zones | | | |
| Item | OK | Hold | Remarks |
| Top Span Mid 1/3 ₇ | | | |
| ¼ Top Span from Corners ₈ | | | |
| Legs ₉ | | | |
| Distribution Steel | | | |
| Item | OK | Hold | Remarks |
| Weld Placemetn ₁₀ | | | |
| Spacers | | | |
| Item | OK | Hold | Remarks |
| Location ₁₁ | | | |
| Size ₁₂ | | | |

1. Not less than 1/2 inch or greater than 2 inches from the ends of each section
2. Not more than 2" from the ends of the three-sided section
3. Not greater than one longitudinal thickness plus 1/4 inch
4. If not tied, welds shall be made to selected circumferential wire not less than 18" apart
5. One longitudinal spacing plus 2 inches or 10 inches, whichever is greater
6. If not tied, welds shall be made to selected circumferential wire not less than 18" a part along longitudinal axis of three-sided section
7. No welding to inside circumferential cage permitted due to high stress
8. No welding to outside circumferential cage permitted due to high stress
9. No welding to outside circumferential cage permitted due to high stress
10. Welds shall only be made to longitudinal wires or bars, and only within 18" from the end of the three-sided section
11. Verify that spacers are in the correct location on the cage per manufacturer's drawings
12. Verify against manufacturer's drawings that the correct size of spacer(s) are used

Three-sided Structure - Arch Deck Reinforcement Inspection

| Identification | |
|-------------------|--|
| Date Cast | |
| Span | |
| Rise | |
| Earth Cover, Min. | |
| Earth Cover, Max. | |

Date: _____

Inspector: _____

Comments: _____

| Circumferential Reinforcing Areas, in ² /ft. | | | | |
|---|----------|------|------------|------------|
| Mark | Required | Used | Mesh Style | Length "L" |
| As1 | | | | |
| As2 | | | | |
| As3 | | | | |
| As4 | | | | |
| As5 | | | | |
| As6 | | | | |
| As7 | | | | |
| As8 | | | | |
| Inserts | | | N/A | N/A |
| Spacers | | | N/A | N/A |

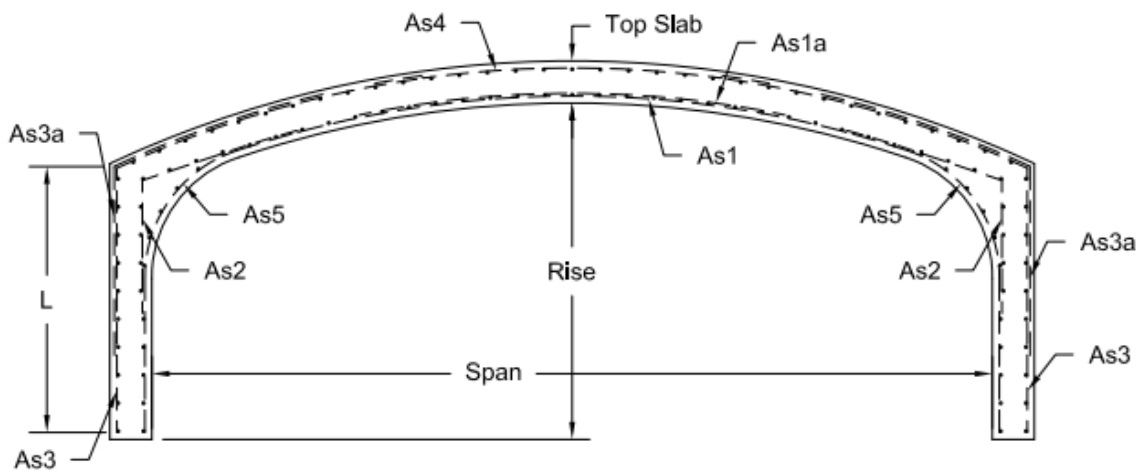

Three-sided Structure - Arch Deck Reinforcement Inspection Cont.

Place a check mark in the box under OK if requirement is met, or a check mark under HOLD if requirement is not met.

| End Cover | | | |
|--|----|------|---------|
| Item | OK | Hold | Remarks |
| Circumferential ₁ | | | |
| Longitudinal ₂ | | | |
| Multiple Layers | | | |
| Item | OK | Hold | Remarks |
| Separation ₃ | | | |
| Weld Placement ₄ | | | |
| Laps | | | |
| Item | OK | Hold | Remarks |
| Min. Lap ₅ | | | |
| Weld Placement ₆ | | | |
| Critical Welding Zones | | | |
| Item | OK | Hold | Remarks |
| Top Span Mid 1/3 ₇ | | | |
| 1/4 Top Span from Corners ₈ | | | |
| Legs ₉ | | | |
| Distribution Steel | | | |
| Item | OK | Hold | Remarks |
| Weld Placement ₁₀ | | | |
| Spacers | | | |
| Item | OK | Hold | Remarks |
| Location ₁₁ | | | |
| Size ₁₂ | | | |

1. Not less than 1/2 inch or greater than 2 inches from the ends of each section
2. Not more than 2" from the ends of the three-sided section
3. Not greater than one longitudinal thickness plus 1/4 inch
4. If not tied, welds shall be made to selected circumferential wire not less than 18" apart
5. One longitudinal spacing plus 2 inches or 10 inches, whichever is greater
6. If not tied, welds shall be made to selected circumferential wire not less than 18" a part along longitudinal axis of three-sided section
7. No welding to inside circumferential cage permitted due to high stress
8. No welding to outside circumferential cage permitted due to high stress
9. No welding to outside circumferential cage permitted due to high stress
10. Welds shall only be made to longitudinal wires or bars, and only within 18" from the end of the three-sided section
11. Verify that spacers are in the correct location on the cage per manufacturer's drawings
12. Verify against manufacturer's drawings that the correct size of spacer(s) are used

Box Culvert Form Pre-Pour/In-Process Pour Inspection - Single Cell

| Identification |
|-------------------|
| Date Cast |
| Span |
| Rise |
| Design, Table # |
| Earth Cover, Min. |
| Earth Cover, Max. |

Date: _____
 Inspector: _____

| Form Dimensional Inspection**** | | |
|---------------------------------|----------|----------|
| Location | Required | Measured |
| T _t | | |
| T _b | | |
| T _{s1} | | |
| T _{s2} | | |
| D ₁ | | |
| D ₂ | | |
| Cover _t | | |
| Cover | | |
| Haunch Size, H | | |
| Span | | |
| Rise | | |

****Required at initial set-up for each production run only

| Visual Inspection* | | | |
|---------------------------|-------|----------|---------|
| Item | Ok | Hold | Remarks |
| Cage Orientation | | | |
| Form Release | | | |
| Embedded Items | | | |
| Form Cleanliness | | | |
| Reinforcing Cover | | | |
| *Initial Appropriate Box | | | |
| Concrete Inspection | | | |
| Item | Spec. | Measured | |
| Slump | | | |
| Entrained Air** | | | |
| Temperature | | | |
| Unit Weight | N/A | | |
| Specified Design Strength | | | |

** If additional tests are taken, they shall be recorded on a separate sheet referencing the respective product information.

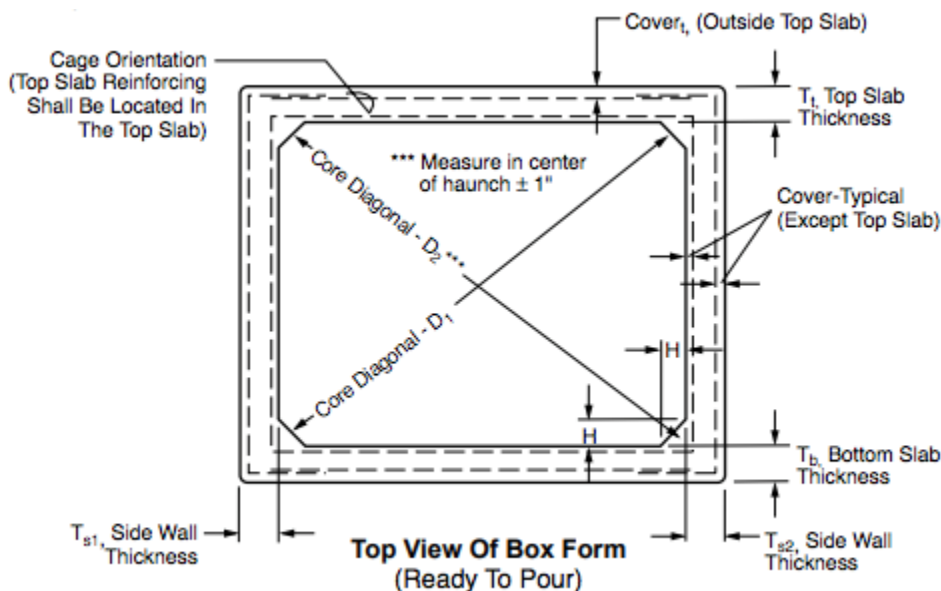

Box Culvert Form Pre-Pour/In-Process Pour Inspection - Double Cell

| Identification |
|-------------------|
| Date Cast |
| Span |
| Rise |
| Design, Table # |
| Earth Cover, Min. |
| Earth Cover, Max. |

Date: _____
 Inspector: _____

| Form Dimensional Inspection**** | | |
|---------------------------------|----------|----------|
| Location | Required | Measured |
| T _t | | |
| T _b | | |
| T _{s1} | | |
| T _{s2} | | |
| D ₁ | | |
| D ₂ | | |
| D ₃ | | |
| D ₄ | | |
| Cover _t | | |
| Cover | | |
| Haunch Size, H | | |
| Span | | |
| Rise | | |

****Required at initial set-up for each production run only

| Visual Inspection* | | | |
|---------------------------|-------|----------|---------|
| Item | Ok | Hold | Remarks |
| Cage Orientation | | | |
| Form Release | | | |
| Embedded Items | | | |
| Form Cleanliness | | | |
| Reinforcing Cover | | | |
| *Initial Appropriate Box | | | |
| Concrete Inspection | | | |
| Item | Spec. | Measured | |
| Slump | | | |
| Entrained Air** | | | |
| Temperature | | | |
| Unit Weight | N/A | | |
| Specified Design Strength | | | |

** If additional tests are taken, they shall be recorded on a separate sheet referencing the respective product information.

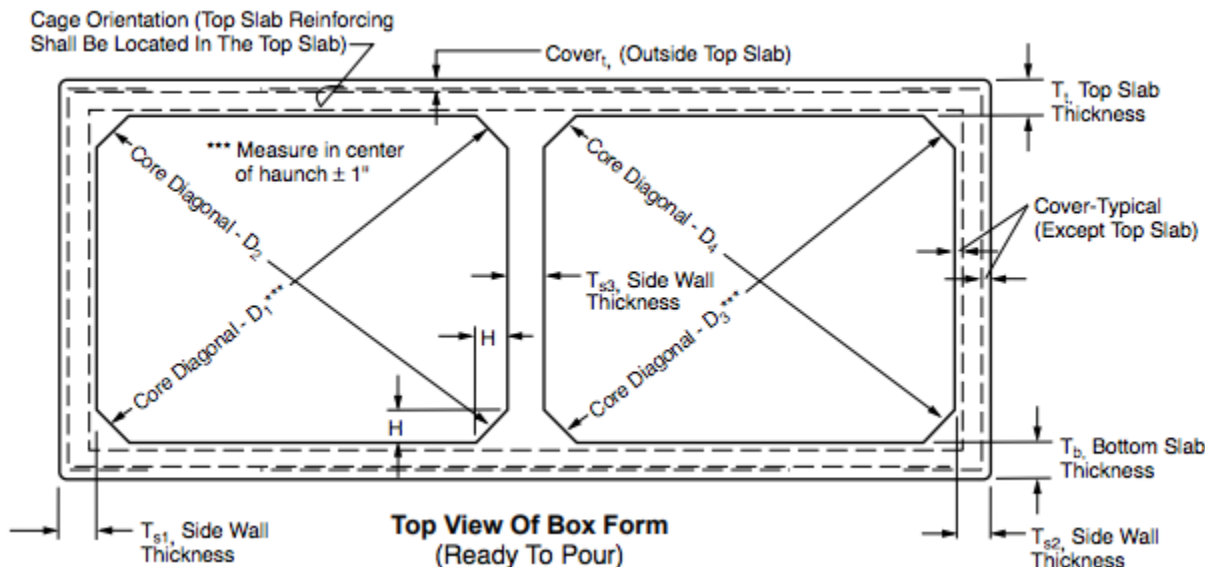

Three-sided Structure - Flat Deck Pre-Pour/ In-Process Pour Inspection

| Identification | |
|-------------------|--|
| Date Cast | |
| Span | |
| Rise | |
| Earth Cover, Min. | |
| Earth Cover, Max. | |

Date: _____

Inspector: _____

| Form Dimensional Inspection**** | | |
|---------------------------------|----------|----------|
| Location | Required | Measured |
| Top | | |
| T _{s1} | | |
| T _{s2} | | |
| H _{1s1} | | |
| H _{2s1} | | |
| H _{1s2} | | |
| H _{2s2} | | |
| H _{s1} | | |
| H _{s2} | | |
| W _t | | |
| W _b | | |
| Cover | | |
| Span | | |
| Rise | | |

****Required at initial set-up for each production run only

| Visual Inspection* | | | |
|--------------------|----|------|---------|
| Item | Ok | Hold | Remarks |
| Cage Orientation | | | |
| Form Release | | | |
| Embedded Items | | | |
| Form Cleanliness | | | |
| Reinforcing Cover | | | |

*Initial Appropriate Box

| Concrete Inspection | | |
|---------------------------|-------|----------|
| Item | Spec. | Measured |
| Slump | | |
| Entrained Air** | | |
| Temperature | | |
| Unit Weight | N/A | |
| Specified Design Strength | | |

** If additional tests are taken, they shall be recorded on a separate sheet referencing the respective product information.

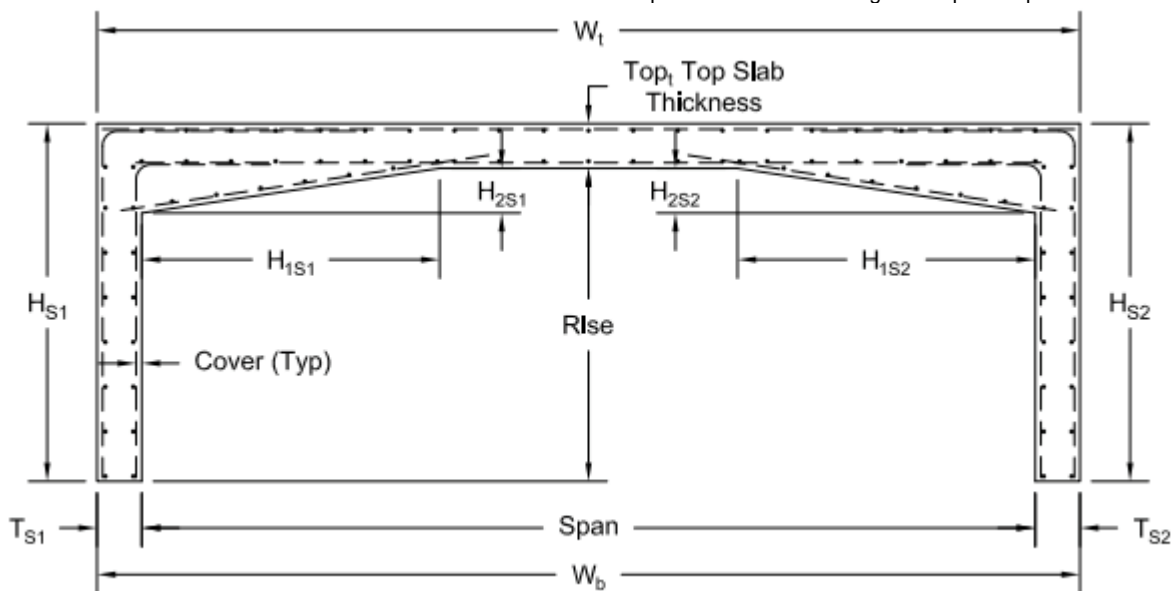

Side View of Form (Ready to Pour)

Three-sided Structure - Arch Deck Pre-Pour/ In-Process Pour Inspection

| Identification | |
|-------------------|--|
| Date Cast | |
| Span | |
| Rise | |
| Earth Cover, Min. | |
| Earth Cover, Max. | |

Date: _____

Inspector: _____

| Form Dimensional Inspection**** | | |
|---------------------------------|----------|----------|
| Location | Required | Measured |
| Top | | |
| T _{s1} | | |
| T _{s2} | | |
| H _{s1} | | |
| H _{s2} | | |
| W _t | | |
| W _b | | |
| Rise | | |
| Span | | |
| Cover | | |

****Required at initial set-up for each production run only

| Visual Inspection* | | | |
|--------------------|----|------|---------|
| Item | Ok | Hold | Remarks |
| Cage Orientation | | | |
| Form Release | | | |
| Embedded Items | | | |
| Form Cleanliness | | | |
| Reinforcing Cover | | | |

*Initial Appropriate Box

| Concrete Inspection | | |
|---------------------------|-------|----------|
| Item | Spec. | Measured |
| Slump | | |
| Entrained Air** | | |
| Temperature | | |
| Unit Weight | N/A | |
| Specified Design Strength | | |

** If additional tests are taken, they shall be recorded on a separate sheet referencing the respective product information.

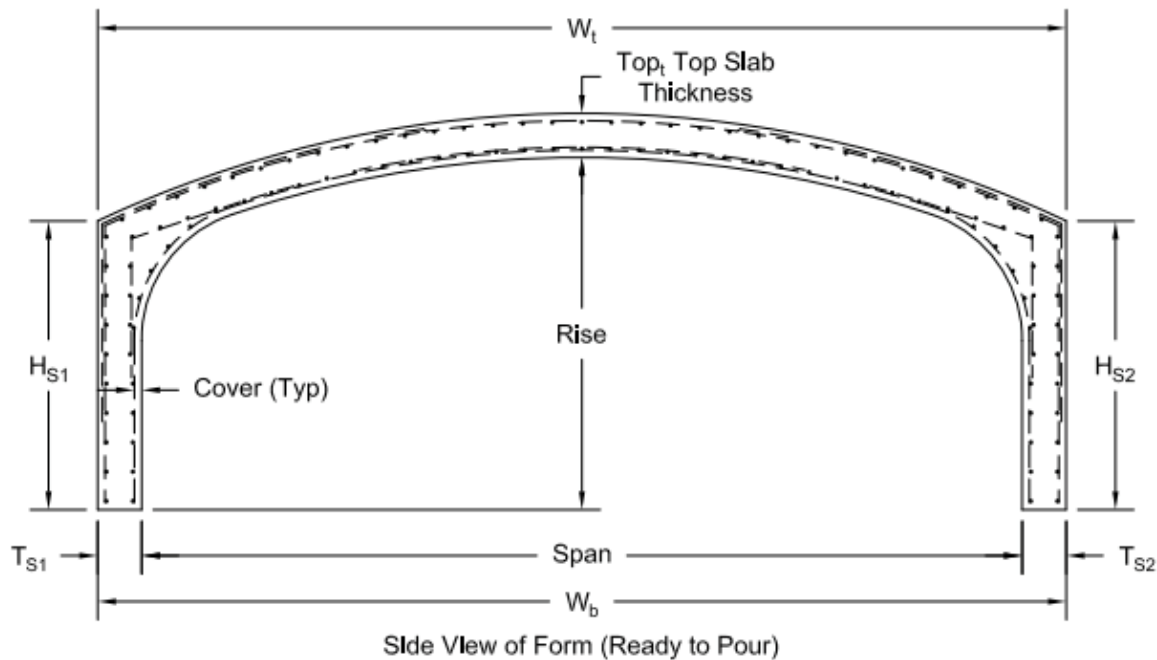

Concrete Quality Control Report

Mix Name _____

PSI _____

Date _____

Inspector _____

Target Mix Report: Cement _____ lbs Air Entraining _____
 Pozzolan _____ lbs Water oz/cwt
 ¾ Rock Coarse _____ lbs Reducer _____ oz/cwt
 Aggregate _____ lbs
 Sand _____ gallons
 Water

| Date Cast | Cylinder ID | Age (Days) | Compress Strength (psi) | Slump (Inches) | Air Content | Conc. Temp. | Vib. or Rod | Batch Information | | | | | |
|-----------|-------------|------------|-------------------------|----------------|-------------|-------------|-------------|-------------------|-----|----------------|-----|--------|--|
| | | | | | | | | Cement | lbs | Water | gal | | |
| | | 1 Day | | | | | | | | | | | |
| | | 1 Day | | | | | | Pozzolan | lbs | Super | | oz/cwt | |
| | | 7 Days | | | | | | Sand | lbs | Water Reducer | | oz/cwt | |
| | | 7 Days | | | | | | 3/4 Rock | lbs | Air Entraining | | oz/cwt | |
| | | 28 Days | | | | | | | | | | | |
| | | 28 Days | | | | | | | | | | | |

| Date Cast | Cylinder ID | Age (Days) | Compress Strength (psi) | Slump (Inches) | Air Content | Conc. Temp. | Vib. or Rod | Batch Information | | | | | |
|-----------|-------------|------------|-------------------------|----------------|-------------|-------------|-------------|-------------------|-----|----------------|-----|--------|--|
| | | | | | | | | Cement | lbs | Water | gal | | |
| | | 1 Day | | | | | | | | | | | |
| | | 1 Day | | | | | | Pozzolan | lbs | Super | | oz/cwt | |
| | | 7 Days | | | | | | Sand | lbs | Water Reducer | | oz/cwt | |
| | | 7 Days | | | | | | 3/4 Rock | lbs | Air Entraining | | oz/cwt | |
| | | 28 Days | | | | | | | | | | | |
| | | 28 Days | | | | | | | | | | | |

| Date Cast | Cylinder ID | Age (Days) | Compress Strength (psi) | Slump (Inches) | Air Content | Conc. Temp. | Vib. or Rod | Batch Information | | | | | |
|-----------|-------------|------------|-------------------------|----------------|-------------|-------------|-------------|-------------------|-----|----------------|-----|--------|--|
| | | | | | | | | Cement | lbs | Water | gal | | |
| | | 1 Day | | | | | | | | | | | |
| | | 1 Day | | | | | | Pozzolan | lbs | Super | | oz/cwt | |
| | | 7 Days | | | | | | Sand | lbs | Water Reducer | | oz/cwt | |
| | | 7 Days | | | | | | 3/4 Rock | lbs | Air Entraining | | oz/cwt | |
| | | 28 Days | | | | | | | | | | | |
| | | 28 Days | | | | | | | | | | | |

| Date Cast | Cylinder ID | Age (Days) | Compress Strength (psi) | Slump (Inches) | Air Content | Conc. Temp. | Vib. or Rod | Batch Information | | | | | |
|-----------|-------------|------------|-------------------------|----------------|-------------|-------------|-------------|-------------------|-----|----------------|-----|--------|--|
| | | | | | | | | Cement | lbs | Water | gal | | |
| | | 1 Day | | | | | | | | | | | |
| | | 1 Day | | | | | | Pozzolan | lbs | Super | | oz/cwt | |
| | | 7 Days | | | | | | Sand | lbs | Water Reducer | | oz/cwt | |
| | | 7 Days | | | | | | 3/4 Rock | lbs | Air Entraining | | oz/cwt | |
| | | 28 Days | | | | | | | | | | | |
| | | 28 Days | | | | | | | | | | | |

Pipe and Manhole Post-Pour Dimension Inspection Instructions

Length of Pipe & Length of Two Opposite Side Measurements

The length of pipe, and the length of two opposite sides, are determined by measuring along the inside of the pipe. Any flashing present at the bell and spigot faces shall be removed. With the aid of a second person, four measurements are to be recorded at 90-degree increments around the inside circumference. The longest and shortest measurements are recorded as the length of two opposite sides. The difference between these two measurements indicates the variation in laying length of two opposite sides.

Internal Diameter

The internal diameter is determined by placing the end of a measuring device at a point on the inside of the pipe and recording the longest measurement to the opposite inside edge of the pipe. Two measurements shall be taken at 90-degree increments on both ends of the pipe.

Wall Thickness

The wall thickness is to be measured at the spigot end. If the bell does not interfere, this measurement shall also be measured and recorded for the bell end. Wall thickness is determined by projecting along the outside of the pipe with a straight edge beyond the spigot face. The measurement taken from the inside of wall, across the spigot face to the projecting straight edge, is the wall thickness. Wall thickness shall be determined at four points around the pipe circumference, at 90-degree increments.

Specification

Specification requirements shall be recorded and compared to product measurements. Failing dimensions shall be circled.

Pipe and Manhole Post-Pour Dimension Inspection Form

Pipe Size _____ Pipe # _____

Pipe Class _____

Pipe Wall _____

Method/Date of Manufacture _____

Date _____

Inspector _____

Length Measurements

| Position | | Measured | Specification |
|----------|-------|------------------|---------------|
| 0° | _____ | Max length _____ | _____ |
| 90° | _____ | Min Length _____ | _____ |
| 180° | _____ | Variation _____ | _____ |
| 270° | _____ | | |

Internal Diameter

| Position | Spigot End | Bell End | Specification |
|----------|------------|----------|---------------|
| 0° | _____ | _____ | _____ |
| 90° | _____ | _____ | _____ |

Wall Thickness

| Position | Spigot End | Bell End | Specification |
|----------|------------|----------|---------------|
| 0° | _____ | _____ | _____ |
| 90° | _____ | _____ | _____ |
| 180° | _____ | _____ | _____ |
| 270° | _____ | _____ | _____ |

Box Culvert Post-Pour Dimension Inspection - Double Cell

| Identification | |
|-------------------|--|
| Date Cast | |
| Span | |
| Rise | |
| Design, Table # | |
| Earth Cover, Min. | |
| Earth Cover, Max. | |

Date: _____
 Inspector: _____
 Total Number of Boxes Produced: _____

| Product Dimensional Inspection | | | | | | | | |
|--------------------------------|-----------|------|------------|---|------------|---|-------------|----|
| Location | Specified | | Measured | | | | Meets Specs | |
| | Min. | Max. | Tongue End | | Groove End | | Yes | No |
| | | | A | B | A | B | | |
| T _t | | | | | | | | |
| T _b | | | | | | | | |
| T _{s1} | | | | | | | | |
| T _{s2} | | | | | | | | |
| Length, Top | | | | | | | | |
| Length, Bottom | | | | | | | | |
| Difference | | | | | | | | |
| Length, S ₁ | | | | | | | | |
| Length, S ₂ | | | | | | | | |
| Difference | | | | | | | | |
| Span, I.D. | | | | | | | | |
| Rise, I.D. | | | | | | | | |

| Visual Inspection* | | | |
|--------------------|----|------|---------|
| Appearance | Ok | Hold | Remarks |
| Cracks | | | |
| Voids/Bleeding | | | |
| Flashing | | | |
| Slumping | | | |
| Exposed Steel | | | |
| Bug Holes | | | |

*Initial Correct Box

| Concrete Inspection | | |
|---------------------|---------------|----------|
| Cylinder ID | Comp Strength | Age/Days |
| | | |
| | | |
| | | |
| | | |
| | | |
| | | |
| | | |
| | | |
| | | |
| | | |

Design Strength

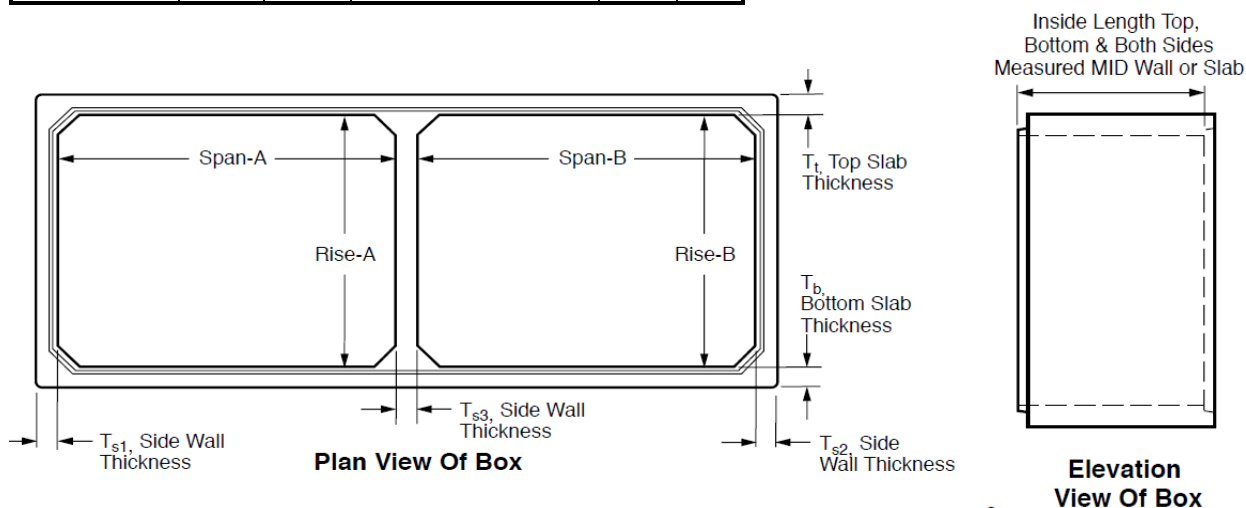

Three-sided Structure - Flat Deck Post-Pour/Pour Dimension Inspection

| |
|-----------------------|
| Identification |
| Date Cast |
| Span |
| Rise |
| Earth Cover, Min. |
| Earth Cover, Max. |

Date: _____
Inspector: _____

| Product Dimensional Inspection | | | | | | |
|--------------------------------|-----------|------|----------|-------|-------------|----|
| Location | Specified | | Measured | | Meets Specs | |
| | Min. | Max. | End 1 | End 2 | Yes | No |
| Top _t | | | | | | |
| T _{s1} | | | | | | |
| T _{s2} | | | | | | |
| H _{s1} | | | | | | |
| H _{s2} | | | | | | |
| L _t | | | | | | |
| L _{s1} | | | | | | |
| L _{s2} | | | | | | |
| Diff. | | | | | | |
| Span | | | | | | |
| Rise | | | | | | |

| Visual Inspection* | | |
|--------------------------|---------------|----------|
| Appearance | Ok | Hold |
| Cracks | | |
| Voids/Bleeding | | |
| Flashing | | |
| Slumping | | |
| Exposed Steel | | |
| Bug Holes | | |
| *Initial Appropriate Box | | |
| Concrete Inspection | | |
| Cylinder ID | Comp Strength | Age/Days |
| | | |
| | | |
| | | |
| | | |
| | | |
| Design Strength | | |

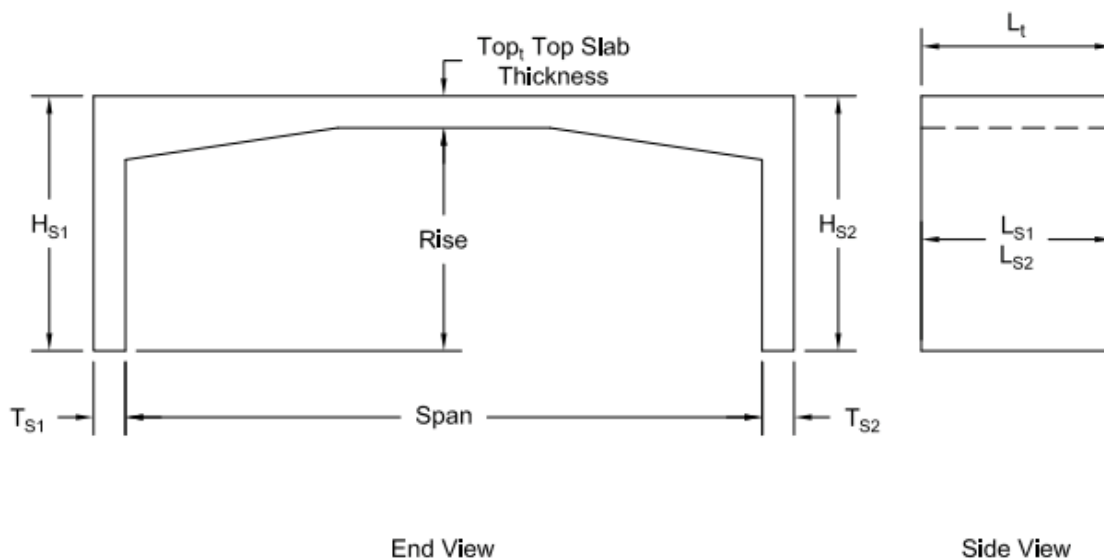

Three-sided Structure - Arch Deck Post-Pour/Pour Dimension Inspection

| |
|-----------------------|
| Identification |
| Date Cast |
| Span |
| Rise |
| Earth Cover, Min. |
| Earth Cover, Max. |

Date: _____
 Inspector: _____

| Product Dimensional Inspection | | | | | | |
|--------------------------------|-----------|------|----------|-------|-------------|----|
| Location | Specified | | Measured | | Meets Specs | |
| | Min. | Max. | End 1 | End 2 | Yes | No |
| Top _t | | | | | | |
| T _{s1} | | | | | | |
| T _{s2} | | | | | | |
| H _{s1} | | | | | | |
| H _{s2} | | | | | | |
| L _t | | | | | | |
| L _{s1} | | | | | | |
| L _{s2} | | | | | | |
| Diff. | | | | | | |
| Span | | | | | | |
| Rise | | | | | | |

| Visual Inspection* | | |
|--------------------------|---------------|----------|
| Appearance | Ok | Hold |
| Cracks | | |
| Voids/Bleeding | | |
| Flashing | | |
| Slumping | | |
| Exposed Steel | | |
| Bug Holes | | |
| *Initial Appropriate Box | | |
| Concrete Inspection | | |
| Cylinder ID | Comp Strength | Age/Days |
| | | |
| | | |
| | | |
| | | |
| | | |
| Design Strength | | |

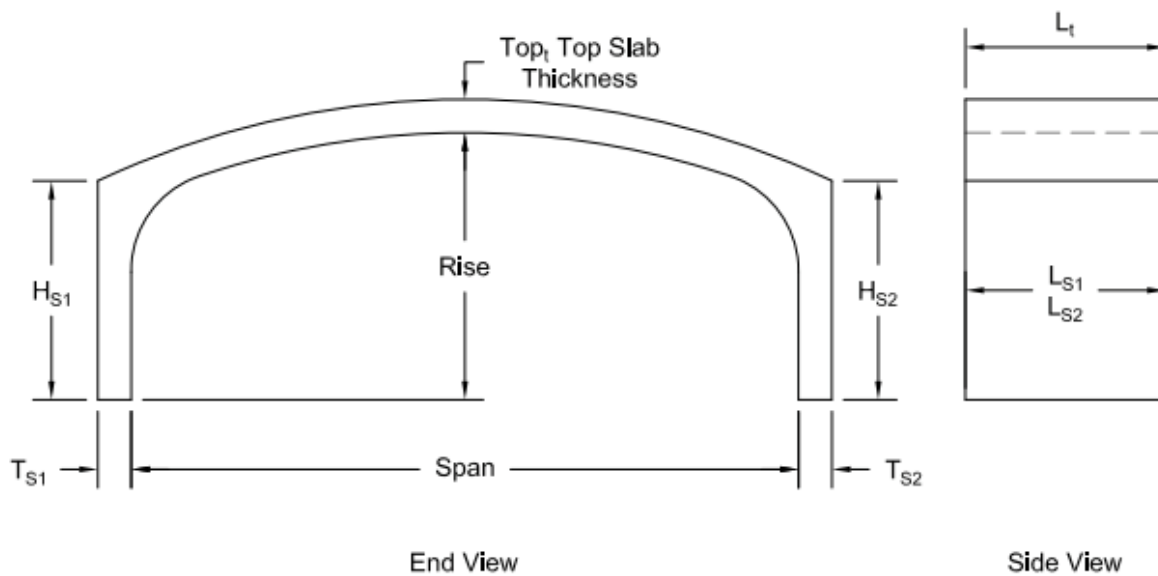

Vacuum Test on Pipe and Manholes with Gasketed Joints

CAUTION: The vacuum test may be dangerous if the pipe or manhole is not prepared properly and proper procedures are not followed.

This procedure covers in-plant testing of concrete sanitary sewer pipe and manholes using the negative air pressure (vacuum) test method. It shall be understood that no exact correlation has been found between air loss and water leakage. Recently cured product shall be allowed to cool to the ambient air temperature for greater test reliability.

If the test criteria is different from this Manual, the plant shall have a written policy that establishes a criteria that meets or exceeds the requirements of the Vacuum Test Table, The plant shall have calculations (theory) that prove their criteria.

Use a vacuum pump to remove air from the bulkheaded pipe. A manometer is recommended to accurately measure the pressure change in a small enough increment to keep test times to a reasonable length. The rate of vacuum loss is used to determine the acceptability of the pipe and manholes.

It shall be noted that relatively inexpensive digital pressure gauges have been recently developed. While they are not as accurate as manometers, they will work for the purpose of this test. The plant shall have a written procedure on file describing calibration and use of digital pressure gauges.

Remove air until the internal air pressure is lowered to approximately 8 inches of mercury. Allow the air pressure and temperature to stabilize, generally 30 seconds to two minutes.

When the pressure and temperature have stabilized, and the pressure is at or below the starting test pressure equivalent to 7 inches of mercury, begin the test by allowing the pressure to increase to the equivalent of 7 inches of mercury, at which point the time recording is initiated. If the pressure increase is less than or equal to 0.1083" Hg* in the test time specified in the table on next page, accept the test specimen.

If the specimen does not pass, either repair and retest or reject it.

* A pressure increase of 0.1083" Hg was chosen because it corresponds to a change in water column height of approximately 1¹/₂" and a change in manometer oil column height (specific gravity 2.945) of 1/2".

Vacuum Test Table

Test Time, Seconds (1)

| <u>Pipe Size</u> | <u>0.0017 CFM/ft² (2)</u> | <u>0.003 CFM/ft² (2)</u> |
|------------------|--------------------------------------|-------------------------------------|
| 12" | 32 | 18 |
| 15" | 41 | 23 |
| 18" | 49 | 28 |
| 21" | 57 | 32 |
| 24" | 64 | 36 |
| 27" | 73 | 41 |
| 30" | 81 | 46 |
| 33" | 90 | 51 |
| 36" | 97 | 55 |
| 42" | 114 | 64 |
| 48" | 128 | 72 |
| 54" | 146 | 82 |
| 60" | 162 | 92 |
| 66" | 180 | 102 |
| 72" | 194 | 110 |
| 78" | 209 | 118 |
| 84" | 226 | 128 |
| 90" | 243 | 138 |
| 96" | 256 | 144 |

- (1) If a larger pressure increase is desired, test times can be increased proportionately.
- (2) Two leakage rates are used in calculating test times because field air and vacuum tests vary by location. The 0.003 CFM/ft² is the ACPA Plant Certification minimum requirement.

Modified Vacuum Test

Plants that wish to modify the ACPA vacuum test requirements may do so as long as their modifications meet the below requirements. The intent of this addendum is to allow for the use of various measuring devices with various units. The intent is not to significantly alter the test.

Starting pressure may be modified from 7" H_g. Acceptable range of pressures shall as follows.

| Acceptable Range of Start Pressure | | | |
|------------------------------------|------|---------|-------|
| Units | Min | Nominal | Max |
| mbar | 200 | 237 | 500 |
| " H _g | 5.91 | 7.00 | 14.77 |
| " Water | 80 | 95 | 201 |
| psi | 2.90 | 3.44 | 7.25 |
| mm H _g | 150 | 178 | 375 |

Lower Forces

Quicker Tests

The ACPA leakage requirements shall be modified linearly to reflect changes in starting pressure as shown below. New test times are then to be calculated using the adjusted requirements.

The change in test pressure may be increased from .01083" H_g up to 1" H_g as desired to accommodate the units and accuracy of gauges, columns, or digital manometers. Acceptable range in test pressure changes is as follows. Gauges must be able to accurately read the change in pressure.

| Acceptable Range of Change in Pressure | | |
|--|----------|---------|
| Units | Min/ Nom | Max |
| mbar | 3.66 | 34.00 |
| " Hg | 0.1083 | 1.0040 |
| " Water | 1.472 | 13.6496 |
| psi | 0.053 | 0.4930 |
| mm Hg | 2.750 | 25.5020 |

Quicker Tests

Better Resolution

Test times can be calculated using the below equation. Where T is the test time, P_{start} is the starting pressure, P_{end} is the ending pressure, P_{atm} is normal atmospheric pressure (1013 mbar), Spec is the Specified leakage rate in standard cubic feet per minute per square foot of internal surface, and d is the ID of the pipe. Plants will be required to document calculations of test times. A Vacuum Test Calculator is available at <http://www.concretepipe.org/qcast/>

$$T = \frac{-(P_{start} - P_{end}) * d_{pipe}}{P_{atm} * S_{peak} * 4}$$

EXAMPLE

A manufacturer was concerned about the condition of fiberglass bulkheads used in production. The manufacturer wanted to reduce the total vacuum on the bulkheads and use units of mbar for his test. A starting test pressure of 200 mbar gauge and a pressure drop of 4 mbar were chosen.

The manufacturer first established an equivalent leakage rate for his desired starting pressure.

$$200\text{mbar} / 237\text{mbar} = .84$$

$$0.0017 \frac{\text{scfm}}{\text{ft}^2} * 0.84 = 0.00143 \frac{\text{scfm}}{\text{ft}^2}$$

The test time was then calculated as shown below

$$T = \frac{-(.200\text{bar} - 0.196\text{bar}) * 6\text{ft}}{1.013\text{bar} * 0.00143 \frac{\text{scfm}}{\text{ft}^2} * 4} \frac{60\text{sec}}{\text{min}} = 249\text{sec}$$

Hydrostatic Testing

Hydrostatic tests shall be run according to the procedure outlined below. Pipe shall be tested to 13 psi for 2-1/2 minutes for Sanitary Sewer (3 psi for 10 minutes for Storm Sewer and Culverts) with no visible leakage. Moisture appearing on the exterior surface of the pipe that does not drip is not considered failing. Up to a 24-hour soak is allowed prior to testing.

Summary of the test method

The section of pipe is subjected to hydrostatic pressure and observed for leakage at the joint or on the surface of the wall. The joint is defined as a connection between adjacent sections of concrete pipe and the watertight seal achieved using rubber gaskets.

1. Determine whether one or two pipe shall be tested. To test the joint, two pipes shall be tested.
2. Clean the joints and inspect them for proper finishing.
3. It is recommended that when two or more pipe are being tested at the same time, the joint shall be opened 1/2". Attach 1/2" spacer blocks to the inside face of the bell.
4. Lubricate the pipe and gaskets if required. Install gaskets and equalize stretch.
4. Assemble pipe on timbers on a level area. Inspect pipe to make sure spacer blocks are still in place.
5. Assemble and restrain bulkheads using an adequate and safe system to resist internal pressure.
6. Fill pipe with water and bleed out all excess air. A bleed tube shall be installed on the top of one of the bulkheads. The bleed tube shall extend above the top of the pipe.
7. Connect pressurizing assembly including a regulator, valve and pressure gauge.
 1. Increase internal water pressure to the specified pressure. Observe test assembly during pressurization to make sure that all components are functioning as intended. The assembly shall remain pressurized for the specified duration of the test.
8. Extreme care shall be taken when testing pipe below 33 degrees F. Test results may be affected by freezing temperatures. The assembly shall be drained before water freezes. Gauges, valves and regulators shall also be protected from freezing temperatures.

NOTE: When the test set-up is unattended for a long period of time, such as overnight, the water supply to the regulator shall be shut off to prevent a possible excess pressure situation due to changes in water supply pressure.

HYDROSTATIC TEST

PLANT _____

DATE _____

PROJECT: _____

OWNER _____ CONTRACTOR _____

DIA X LENGTH: _____ SPECIFICATION: _____

PROCESS: _____ CLASS / WALL: _____

MIX ID: _____

| PIPE DATA | | NO. 1 | NO. 2 |
|--|--------|----------------|-------|
| SINGLE INNER CAGE | OR | AREA USED | |
| | | SIZE & SPACING | |
| OUTER CAGE | | AREA USED | |
| | | SIZE & SPACING | |
| FOG _____ HRS. STEAM _____ HRS. AIR _____ DAYS | CURING | DATE MADE | |
| | | DATE TESTED | |
| | | AGE (DAYS) | |
| | | | |

TYPE OF TEST: FULL BARREL EXTERNAL INTERNAL

| PRESSURE | TIME | PR 1 | PR 2 | JOINT DROPS/MIN | STRAIGHT, DEFLECTED, OFF-CENTER | REMARKS |
|----------|------|------|------|-----------------|---------------------------------|---------|
| | | | | | | |
| | | | | | | |
| | | | | | | |
| | | | | | | |

OFF CENTER TESTING

| POUNDS OF FORCE REQUIRED | POUNDS OF FORCE APPLIED | PASS / FAIL |
|--------------------------|-------------------------|-------------|
| | | |
| | | |
| | | |
| | | |

PR (PERMEABILITY RATING) SCALE

| RATING | DESCRIPTION |
|--------|--|
| 1 | Completely dry. Add + for first damp spot. |
| 2 | A few small damp spots - increase in size not perceptible. No dripping. |
| 3 | Several damp spots up to 4 ft2 in size. Minor dripping from bottom of pipe. (Up to 60 drops/min.) |
| 4 | Numerous wet areas or areas larger than 4 ft2. Perceptible increases in size wet areas. (Dripping faster but not steady stream). |
| 5 | Visible water movement through wall. Steady stream leakage from bottom of pipe. |
| + | Rating judged to be between numerical values. A 4+ would be about half way between 4 and 5. |

SIGNED BY: _____

WITNESSED BY: _____

Certification of Three-Edge-Bearing Test Results of Reinforced Concrete Pipe

Pipe Information

| | | | | |
|------------------|------|-------|------|-------|
| Pipe Description | Size | Class | Wall | Joint |
| | | | | |

Test Number: _____
 Test Location: _____
 Date of Manufacture: _____
 Date Tested: _____
 Age of Pipe (in days): _____
 Method of Fabrication: _____

Optional Dimensional Check

| | Pipe Length | | | | Wall Thickness | | | | Inside Diameter | | | | | |
|-----------------------------------|-------------|--|-----------|--|-------------------|--|-----------|-----|-----------------|------|-----------|--|--|--|
| | Measured | | Allowable | | Measured | | Allowable | | Measured | | Allowable | | | |
| Min. | | | | | Min. | | | | | Min. | | | | |
| Max. | | | | | Max. | | | N/A | | Max. | | | | |
| Diff. in Length of Opposite Sides | | | | | Nominal Thickness | | | | | | | | | |

NOTE: Allowable dimensions are specified dimensions either increased or decreased by the specified tolerance. All dimensions are in inches.

Reinforcing

| Cage | Reinforcing Description | Area | Specified Area |
|-------------|-------------------------|------|----------------|
| Inside: | | | |
| Outside: | | | |
| Elliptical: | | | |

Shear Steel Description and Area: _____

Three-Edge-Bearing Test Results

| | Actual Load | Required Load | Actual D-Load ** | Required D-Load** |
|-----------|-------------|---------------|------------------|-------------------|
| 1st Crack | | | | |
| .01 Crack | | | | |
| Ultimate | | | | |

** D-Load is measured in pounds per linear foot of inside diameter.

If Pipe was not tested to Ultimate:
 Load when test was stopped: _____ lbs
 D-Load when test was stopped: _____ lbs/ft
 Condition of pipe when test has stopped: _____

I hereby certify that the pipe was three-edge bearing tested in accordance with the provisions of ASTM designation C-497

Signature: _____
 Date: _____
 Plant Location: _____

Distribution:

Off Center Joint Test Combined Certification Only

The Off Center Joint test is an evaluation of the capacity of a pipe joint to remain sealed under pressure, with the spigot installed into the bell in the maximum off center position. The test medium may be hydrostatic or vacuum. To perform the test, two test pipes shall be assembled with one pipe fully supported and the spigot end of the second pipe installed in the bell end of the first pipe as illustrated in Figure 2, Appendix A, page 118, and Figure 5, Appendix A, page 120. The test joint shall not be open over 3/4 inch from the design-assembled position. The bell end of the second pipe shall be supported by a block. The supports for the pipes shall maintain a uniform invert elevation for both pipes.

The outer ends of the test pipe assembly shall be closed with bulkheads. For hydrostatic, the bulkheads shall be restrained longitudinally. The longitudinal restraints and bulkheads shall be designed so they do not exert beneficial axial or lateral forces on the test joint assembly. Flat plate bulkheads shall not be used for hydrostatic.

A vertical test load, F , shall be applied to the suspended portion of the test joint until the total differential load, including the weight of the pipe filled with water (hydrostatic testing only) shall be either a minimum 1,800 pounds per foot of pipe diameter or until there is concrete-to-concrete contact within the joint. A method for calculating the test load is shown on Figure 1 and Figure 2, Appendix A, page 118.

The assemblies shall be subjected to one of the following test criteria:

Vacuum Testing Appendix A, page 110 and page 111
Hydrostatic Testing Appendix A, page 114

The pipe support blocks are not required to be contoured, but for safety reasons they shall be constructed to prevent the pipes from rolling from the test position.

CAUTION: The hydrostatic test requires internal pressure to be applied over a large cross-sectional area of pipe bulkheads, creating large axial forces on longitudinal tie rods. Tie rods, bulkheads, and fasteners shall be selected for adequate strength and minimum elongation.

Off Center Joint Test Calculations

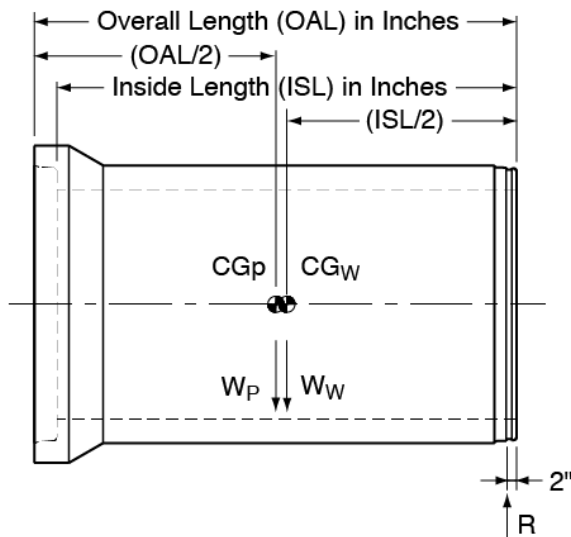
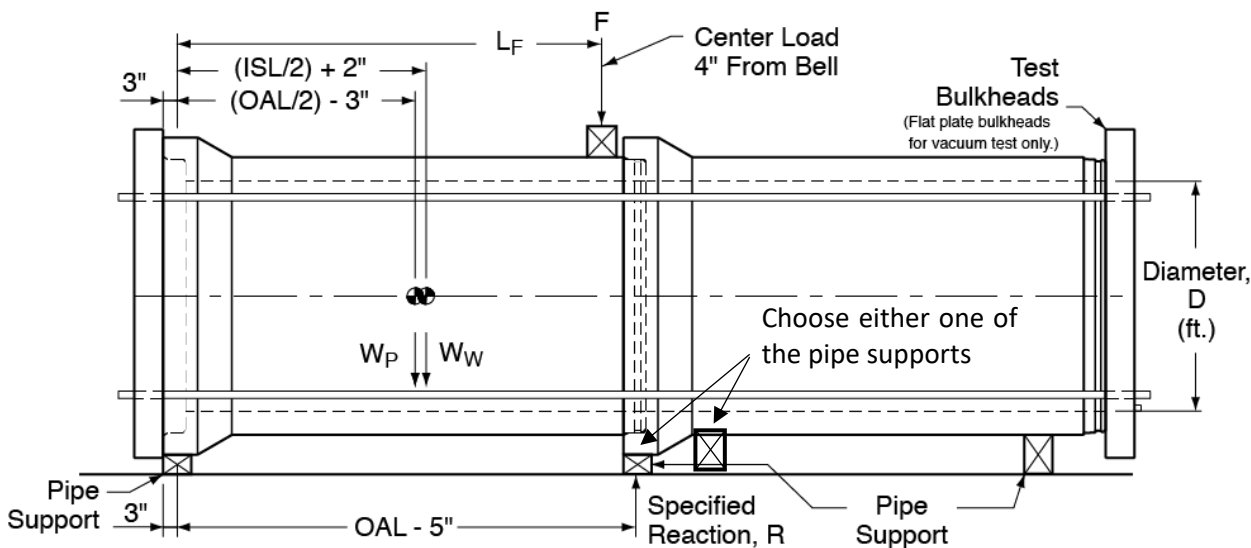

Fig. 1 Simplified Center of Gravity of Pipe Filled With/Without Water



| | |
|--|--|
| R = Test Requirement | $R = 1800 \text{ lbs.} \times \text{Internal Diameter in Feet}$ |
| W_p = Nominal Weight of Test Pipe | |
| W_w = Nominal Weight of Water in Test Pipe | |
| F_h = Additional Test Force for Hydrostatic Test | $F_h = \frac{((OAL) - 5")R - ((OAL/2) - 3")W_p - ((ISL/2) + 2")W_w}{L_F} \text{ (lbs.)}$ |
| F = Additional Test Force for Vacuum | $F = \frac{((OAL) - 5")R - ((OAL/2) - 3")W_p}{L_F}$ |

Fig. 2 Off Center Hydrostatic Joint Test

Joint Shear Test

The Joint Shear test is an evaluation of the capability of a pipe joint to maintain structural strength when subjected to a differential load. To perform the test, two test pipes shall be assembled with one pipe fully supported and the spigot end of the second pipe installed in the bell end of the first pipe as illustrated in Figure 5, Appendix A, page 120. Both pipes shall be supported so a uniform invert elevation is maintained. It is recommended for safety reasons that the pipe supports be constructed as shown on Figure 3 below.

The joint shear test shall be run without water in the pipe or bulkheads installed on the pipe. A vertical test load, F , shall be applied to the suspended portion of the test joint until the total differential load, including the weight of a pipe, is 4,000 pounds per foot of pipe diameter. A method for calculating the test load is shown on Figures 4 and 5, Appendix A, page 120.

The test load shall be applied to the suspended pipe and the assembled joint shall then be inspected for structural integrity. Cracks that occur during the test load are not considered failure, provided those cracks close to 0.01 inch or less on release of the load.

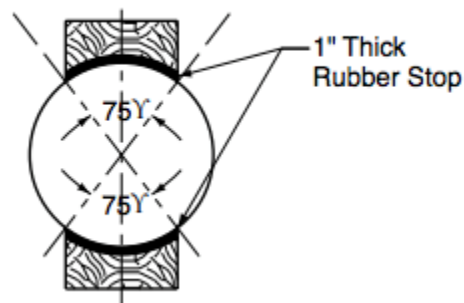
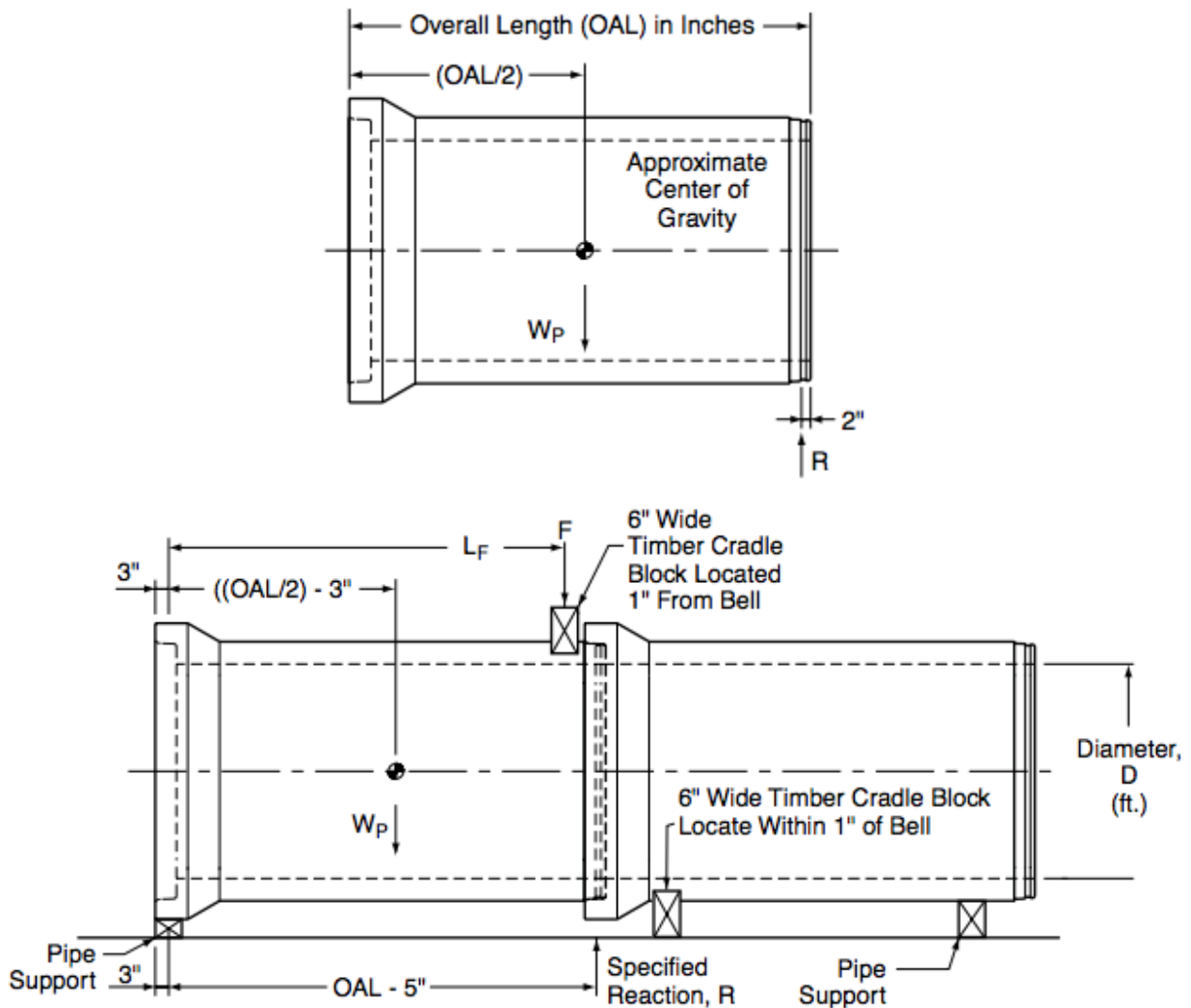

Figure 3 Support Block Configuration

Joint Shear Test Calculations



R = Test Requirement
 Wp = Nominal Weight of Test Pipe
 F = Additional Test Force

R = 4000 lbs. x Internal Diameter in feet

$$F = \frac{[(OAL) - 5"]R - \left[\left(\frac{OAL}{2}\right) - 3"\right]W_p}{L_F} \text{ (lbs.)}$$

Figure 5 Joint Shear Test

Storm Sewer and Culvert Joint Test

The Storm Sewer and Culvert Joint Test is an evaluation of the pipe joint. The test medium may be hydrostatic or vacuum. To perform this test, two pipes shall be assembled in straight and in deflected alignment as defined by the joint being open 1/2" more on one side, than on the opposite side. Hydrostatic testing of the joint may be performed either internally, externally, or using conventional bulkheads, the bulkheads shall be restrained longitudinally.

Both the straight alignment and deflected assemblies shall be subjected to one of the following test criteria:

| | |
|------------------|---|
| Vacuum Test | Appendix A, page 110 and page 111 |
| Hydrostatic Test | 3 psi for 10 minutes and shall have an allowable leakage rate of 200 gallons/(inch of internal diameter) (mile of pipe) (24 hours). The manufacturer shall have the option of allowing the assemblies to stand under 3 psi for up to 24 hours prior to the test. The test shall be performed according to the summary found in Appendix A, page 114. For internal joint test, follow equipment manufacturers recommended procedure. |

CAUTION: The Hydrostatic Test requires internal pressure to be applied over a cross-sectional area of pipe bulkheads, creating large axial forces on longitudinal tie rods. Tie rods, bulkheads, and fasteners shall be selected for adequate strength and minimum elongation.

Equipment Checklist Dry Cast New and Repaired

| Core | Yes/No | Comments |
|---|--------|----------|
| Is the core the correct length? | | |
| Is core the correct diameter? Check with Pi tape and check against manufacturer specifications. | | |
| Does pallet fit over the whole length of the core? | | |
| Is pallet seal in place? | | |
| Does header fit down over core? (Top 10") | | |
| Jacket | | |
| Is jacket the correct length? | | |
| Does pallet fit into guide lugs? | | |
| Do pallet retaining lugs fully engage pallet and retract fully? | | |
| Does header fit into jacket? | | |
| Is all hardware in place and working properly? | | |
| Is jacket stenciled correctly? | | |

Date: _____

By: _____

Equipment Checklist Wet Cast Molds New and Repaired

| Core | Yes/No | Comments |
|---|--------|----------|
| Is core the correct length? Check against manufacturer's specification or measure first product poured. | | |
| Check core fit on pallet | | |
| Does pallet fit over the whole length of the core? | | |
| Does header fit down over core? (Top 10") | | |
| Jacket | | |
| Is jacket the correct length? | | |
| Does header fit into jacket? | | |
| Is all hardware in place and working properly? | | |
| Is jacket stenciled correctly? | | |

Date: _____

By: _____

Appendix B

Audit Expectations

Audit Expectations

1. Quality Documentation, Specifications and Information

The auditors shall verify that specifications, documentation, and other information is current and satisfies the requirements for content and frequency. During the audit the plant procedures shall be demonstrated by the plant staff that would be normally expected to perform these procedures or their backup as defined on the org chart.

2. Materials

The auditor shall verify that all material documentation on file is current and obtained at the required frequency.

3. Calibration

The auditor shall verify that production and testing equipment has been properly and accurately calibrated at the required frequencies. Written procedures for these calibrations shall also be reviewed. The auditor shall verify that the batching equipment has been calibrated through the maximum working range.

4. Mix Designs

The auditor shall review required documentation, including water/cement ratio confirmation, and verify that concrete being produced is the same proportion as mix designs on file.

5. Joints

Pipe and Manholes:

5.1-5.3 Joint/Spigot Gauging Design Drawings and Calculations

The auditor shall review joint design drawings and calculations.

5.4 Gasket Quality Control

The plant shall demonstrate the equipment and procedures for measuring sanitary sewer pipe and sanitary sewer manhole gaskets, except when they are measured by personnel from outside the plant. In the latter case, the procedure and inspection location shall be documented and filed with the Inspection Test Reports.

Precast, Box, and Three-Sided Structures:

The auditor shall review joint design drawings.

6. Equipment

Pipe and Manholes:

6.1 Forms

The auditor shall review plant procedures and required documentation. The auditor shall verify that the equipment is clean and in good operational condition.

6.2 Joint Forming Equipment

The auditor shall witness the equipment and procedures for measuring sanitary sewer pipe and sanitary sewer manhole headers, pallets and truing rings (if used), except when they are measured by personnel from outside the plant. In the latter case, the procedure and inspection location shall be documented and filed with the Inspection Test Reports.

Precast, Box, and Three-Sided Structures:

The auditor shall review plant procedures and required documentation. The auditor shall verify that the equipment is clean and in good operational condition.

7. Reinforcing

7.1 Reinforcing Design

The auditor shall verify that detailed design information for all cages/ reinforcement being fabricated is available in the fabrication area.

8. Pre-Pour Inspection

8.1 Reinforcing Inspection

During the audit, inspection shall be performed on reinforcing produced on the day of the audit. The auditor shall witness reinforcing measuring techniques and verify that cages/reinforcement being produced meet design requirements.

8.2 Pre-Pour Visual Inspection

The auditor shall review the pre-pour visual inspection procedures and documentation.

8.3 Pre-Pour Dimensional Inspection

The auditor shall review the pre-pour dimensional inspection procedures and documentation.

9. Concrete Testing

The auditor shall review required documentation for content and frequency. Plant personnel shall demonstrate quality assurance/quality control competency during the audit by performing all applicable concrete tests.

In-house Tests

For tests that are in-house, but run at a site other than the one being audited, a written procedure shall be on file with the appropriate test results. Tests that are performed by independent labs need not be accompanied by procedural documentation.

Tests to be witnessed include:

Slump or slump flow (wet cast concrete) Air content (wet cast concrete)
Concrete temperature Concrete compression Concrete absorption
Unit weight testing and calculation

10. Curing

The auditor shall review curing documentation and curing practices.

11. Post-Pour Inspection

11.1 Finishing and Repairs

The auditor shall review written repair and finishing procedures and inspect yarded product for the quality of repairs.

11.2 Finished Product Inspection

The auditor shall verify that the plant has functioning procedures in place for the visual inspecting of product. During the audit, the auditor shall inspect the appearance of product in the yard as well as those being prepared or loaded for shipment in order to ensure the product meets the appropriate specification.

11.3 Dimensional Test of Product

The auditor shall witness the technique for measuring product randomly selected by the auditor, and documentation of required ongoing inspections.

11.4 Joint Visual Inspection

Pipe and Manholes:

The auditor shall witness the plant's procedure and equipment for gauging pipe spigots by watching plant personnel gauge pipe or manhole spigots.

Box Culverts and Three-Sided Structures:

The auditor shall witness the assembly of three box culvert sections into one assembly or two box culvert sections for larger boxes having a span greater than 10 feet. The assembly shall fit so that the maximum joint opening at any one point is 1".

12. Product Marking

The auditor shall inspect yarded product for required marking.

13. Product Testing - Pipe and Manhole Only

This Manual includes an audit of inspection and tests performed by the plant on finished product. Since the set-up of finished product tests requires considerable time and effort, the auditor shall randomly select pipe to be tested on the onset of the audit. This shall allow adequate time for plant personnel to set up for afternoon testing.

13.1 Water Tightness of Pipe – Sanitary Sewer

For each test procedure, the auditor shall witness the plant's procedure, equipment and reporting for measuring the water tightness of product selected for test by the inspector.

The plant shall also demonstrate through documentation, that pressure change measuring equipment and testing time meet the minimum requirements of this Manual.

13.2 Three-Edge-Bearing Testing of Pipe

The auditor shall witness the plant's procedures, equipment and reporting for measuring the three-edge-bearing strength up to a 0.01-in. crack width of one pipe selected for test by the auditor. Prior to performing the test, the auditor shall witness dimensional measurements of the pipe section being tested.

13.3 Off-Center Joint Test - Sanitary Sewer

The auditor shall witness the plant's procedure, equipment and reporting for the off-center joint test of a single set-up consisting of two pipes selected by the auditor. Test medium may be hydrostatic or vacuum.

13.4 Differential Joint Shear Test - Sanitary Sewer

The auditor shall witness the plant's procedure, equipment and reporting for the differential joint shear test of a single set-up consisting of two pipes selected by the auditor.

13.5 Storm Sewer and Culvert Joint Test - Storm and Culvert

The auditor shall witness the plant's procedure, equipment and reporting for the storm sewer and culvert joint test of a single set-up consisting of two gasketed pipe selected by the auditor.

14. Storage, Handling, Shipping and Final Inspection

14.1 Handling and Storage

The auditor shall inspect product handling operations, to ensure that they meet the requirements of this Manual.

14.2 Shipping Policy

The auditor shall review the plants shipping policy and verify that product being shipped meets the requirements of that policy.

14.3 Final Inspection

The auditor shall verify that the plant has a policy and functioning procedure in place for final inspection of product.

ACPA Audits

ACPA audits are conducted to verify conformance with applicable specification including QCast requirements and to provide meaningful feedback on current quality practices of a plant. Audits are an important piece of the QCast program and plant quality control systems. However, plants are ultimately responsible for the quality of the product that they produce and adherence to applicable specification including the QCast program. The ACPA does not presume the authority to alter plant quality systems only to verify conformance to applicable standards.

Audit Feedback and Report:

ACPA auditors are tasked with providing meaningful feedback to member plants. There are several opportunities for the auditing agency to provide feedback during the audit, during the report out meeting, and in the audit report.

Feedback and discussion are ongoing during the audit. Auditors will answer all questions to the best of their ability and explain in detail the expectations of relevant specifications.

At the conclusion of every audit there is an exit interview in which the auditor, plant management and plant quality staff, go through the auditor's observations in detail. This process allows plants to receive immediate feedback on the state of their quality functions.

After the audit, a detailed written report is sent to the plant. The report will indicate whether the plant met the requirements of QCast certification, provide a written account of the auditor's observations, and it will contain the certification score(s).

The Audit Report:

The first page of the audit report is a cover letter indicating whether or not the plant met the requirements of QCast certification. For plants not meeting the requirements the letter will describe a plant's options for continuing certification as outlined in the bylaws.

The first section of the audit report deals with Deficiencies. Deficiencies as defined below are serious nonconformances that may be affecting the quality of the product. Deficiencies must be corrected, and a response must be sent to the ACPA within 30 days for a plant to maintain certification.

Critical Items - Program elements that must be in place to ensure product quality. They include concrete strength, fresh concrete testing, fabrication of reinforcement, positioning of reinforcement, reinforcing steel inspection, certain proof of manufacture, proof of design testing, pre-pour inspection for all products, and post-pour dimensional inspection of box culverts. Critical items are specifically listed in the audit grade sheets in Appendix B of the QCast manual. The plant must pass all critical items with a grade of 75 or higher to pass the audit. If a plant is not doing an adequate job on a critical item (scores less than 75), the plant fails the audit, even if the total combined score of the audit is satisfactory. Failure of critical items are not related to the Deficiencies cited in the audit report.

Deficiencies can occur for critical items without failing that critical item. This would result in a grade decrease, but the plant would not fail the audit unless the critical item evaluation fell below a score of 75.

Deficiency - Failure to adequately implement or maintain a requirement(s) of QCast certification that raises significant doubt as to the effectiveness of the producer's quality system and any finished product or component found out of specification. Every repeated deficiency will have a reduction of 0.25% points from the final score.

The next section of the audit report includes all opportunity for improvement items.

Opportunity for Improvement - Any failure to meet the QCast requirements that is an isolated occurrence and does not qualify as a breakdown in the quality system or have a direct impact on the product quality.

The third section of the audit report is a transcript of the auditor's comments.

At the end of the audit are score summary sheets. Plants receiving deficiencies in a particular area will see reductions in scores. Plant certification is dependent on the audit score of 80% as described in the bylaws.

Audit Manual Score Summary Sheet Pipe Requirements

Plant _____

Date of Audit _____

Location _____

Inspector _____

| Section | Description | Possible Points (A) | Grade (B) | Score (A x B) |
|---|--|---------------------|-----------|---------------|
| Product Documentation | | | | |
| 1.0 | Quality Control Documents & Info. | 4 | | |
| 2.0 | Raw Materials | 3 | | |
| 3.0 | Calibration | 4 | | |
| 4.0 | Mix Designs | 4 | | |
| Joints | | | | |
| 5.1 | Joint Design Drawings | 2 | | |
| 5.2 | Joint Design Calculations (SS) | 2 | | |
| 5.3 | Spigot Gauge System (SS) | 2 | | |
| 5.4 | Gasket Quality Control & Testing | 3 | | |
| Equipment | | | | |
| 6.1 | Forms | 3 | | |
| 6.2 | Joint Forming Equipment Inspection | 4 | | |
| Pre-Pour Product Inspection | | | | |
| 7.0 | Reinforcing ¹ | 6 | | |
| 7.1 | In-Plant Drawn Wire | 2 | | |
| 8.0 | Pre-Pour Inspection ¹ | 6 | | |
| 9.0 | Concrete Testing ^{1,4} | 6 | | |
| 9.9 | Compressive Strength Testing ¹ | 6 | | |
| Post-Pour Product Inspection | | | | |
| 10.0 | Curing | 4 | | |
| 11.1 | Repairs and Finishing | 2 | | |
| 11.2,11.4 | Product Visual Inspection | 2 | | |
| 11.3 | Dimensional Test Reports | 2 | | |
| 11.5 | Sanitary Joint Dimensional Inspection (SS) | 2 | | |
| 12.0 | Product Marking | 3 | | |
| Product Testing | | | | |
| 13.1 | Water Tightness Test ¹ (SS) | 6 | | |
| 13.2 | Three Edge Bearing Test ¹ | 6 | | |
| 13.3 | Off Center Joint Test ¹ (SS) | 6 | | |
| 13.4 | Differential Joint Shear Test ¹ (SS) | 6 | | |
| 13.5 | Storm & Sewer Joint Test (S) | 6 | | |
| Storage, Handling, Shipping and Final Inspection | | | | |
| 14.1 | Storage and Handling | 3 | | |
| 14.2 | Shipping Policy | 3 | | |
| 14.3 | Final Inspection | 3 | | |
| | Total Applicable Points | 111 | | |
| | Repeated deficiency score reduction ³ | | | |
| | Adjusted Score ² | | | |

Notes:

¹Critical Element: Minimum Passing Score = 4.5

² Minimum Passing Score = 80, Conditional Certification Score = 75

³ Every repeated deficiency will have a reduction of 0.25% points from the final score.

⁴ Score for drycast concrete temperature testing is included in section 9.0

(SS) = Sanitary Sewer Pipe Only

(S) = Storm Sewer and Culvert Only

Note: If grade is marked "NA", possible points will not be added to the total score.

Audit Manual Score Summary Sheet Manhole Requirements

Plant _____

Date of Audit _____

Location _____

Inspector _____

| Section | Description | Possible Points (A) | Grade (B) | Score (A x B) |
|---|--|---------------------|-----------|---------------|
| Product Documentation | | | | |
| 1.0 | Quality Control Documents & Info. | 4 | | |
| 2.0 | Raw Materials | 3 | | |
| 3.0 | Calibration | 4 | | |
| 4.0 | Mix Designs | 4 | | |
| Joints | | | | |
| 5.1 | Joint Design Drawings | 2 | | |
| 5.2 | Joint Design Calculations (SS) | 2 | | |
| 5.3 | Spigot Gauge System (SS) | 2 | | |
| 5.4 | Gasket Quality Control & Testing | 3 | | |
| Forming Equipment | | | | |
| 6.1 | Forms | 3 | | |
| 6.2 | Joint Forming Equipment Inspection | 4 | | |
| Pre-Pour Product Inspection | | | | |
| 7.0 | Reinforcing ¹ | 6 | | |
| 8.0 | Pre-Pour Inspection ¹ | 6 | | |
| 9.0 | Concrete Testing ^{1,4} | 6 | | |
| 9.9 | Compressive Strength Testing ¹ | 6 | | |
| Post-Pour Product Inspection | | | | |
| 10.0 | Curing | 4 | | |
| 11.1 | Repairs and Finishing | 2 | | |
| 11.2, 11.4 | Product Visual Inspection | 2 | | |
| 11.3 | Product Dimensional Inspection | 2 | | |
| 11.5 | Sanitary Joint Dimensional Inspection (SS) | 2 | | |
| 12.0 | Product Marking | 3 | | |
| Product Testing | | | | |
| 13.1 | Water Tightness Test ¹ (SS) | 6 | | |
| 13.2 | Manhole Step Test | 2 | | |
| Storage, Handling, Shipping and Final Inspection | | | | |
| 14.1 | Storage and Handling | 3 | | |
| 14.2 | Shipping Policy | 3 | | |
| 14.3 | Final Inspection | 3 | | |
| | Total Applicable Points | 87 | | |
| | Repeated deficiency score reduction ³ | | | |
| | Adjusted Score ² | | | |

Notes:

¹Critical Element: Minimum Passing Score = 4.5

²Minimum Passing Score = 80, Conditional Certification Score = 75

³ Every repeated deficiency will have a reduction of 0.25% points from the final score.

⁴ Score for drycast concrete temperature testing is included in section 9.0

(SS) = Sanitary Sewer Pipe Only and Sanitary Sewer Manhole Only

Note: If grade is marked "NA", possible points will not be added to the total score.

Audit Manual Score Summary Sheet Engineered Precast Requirements

Plant _____

Date of Audit _____

Location _____

Inspector _____

| Section | Description | Possible Points (A) | Grade (B) | Score (A x B) |
|---|--|---------------------|-----------|---------------|
| Product Documentation | | | | |
| 1.0 | Quality Control Documents & Info. | 4 | | |
| 2.0 | Raw Materials | 3 | | |
| 3.0 | Calibration | 4 | | |
| 4.0 | Mix Designs | 4 | | |
| Joints | | | | |
| 5.0 | Joints | 3 | | |
| 6.0 | Equipment | 2 | | |
| Pre-Pour Product Inspection | | | | |
| 7.0 | Reinforcing ¹ | 6 | | |
| 8.0 | Pre-Pour Inspection ¹ | 6 | | |
| 9.0 | Concrete Testing ^{1,4} | 6 | | |
| 9.9 | Compressive Strength Testing ¹ | 6 | | |
| Post-Pour Product Inspection | | | | |
| 10.0 | Curing | 4 | | |
| 11.1 | Repairs and Finishing | 2 | | |
| 11.2, 11.4 | Product Visual Inspection | 2 | | |
| 11.3 | Dimensional Test Reports | 2 | | |
| 12.0 | Product Marking | 3 | | |
| Storage, Handling, Shipping and Final Inspection | | | | |
| 14.1 | Storage and Handling | 3 | | |
| 14.2 | Shipping Policy | 3 | | |
| 14.3 | Final Inspection | 3 | | |
| | Total Applicable Points | 66 | | |
| | Repeated deficiency score reduction ³ | | | |
| | Adjusted Score ² | | | |

Notes:¹Critical Element: Minimum Passing Score = 4.5²Minimum Passing Score = 80, Conditional Certification Score = 75³ Every repeated deficiency will have a reduction of 0.25% points from the final score.⁴ Score for drycast concrete temperature testing is included in section 9.0

Note: If grade is marked "NA", possible points will not be added to the total score.

Audit Manual Score Summary Sheet Box Culvert and Three-Sided Structure Requirements

Plant _____

Date of Audit _____

Location _____

Inspector _____

| Section | Description | Possible Points (A) | Grade (B) | Score (A x B) |
|---|--|---------------------|-----------|---------------|
| Product Documentation | | | | |
| 1.0 | Quality Control Documents & Info. | 4 | | |
| 2.0 | Raw Materials | 3 | | |
| 3.0 | Calibration | 4 | | |
| 4.0 | Mix Designs | 4 | | |
| Joints | | | | |
| 5.1 | Joint Design Drawings | 2 | | |
| 5.2 | Joint Design Calculations ³ | 2 | | |
| 5.4 | Gasket Quality Control and Testing ³ | 3 | | |
| Forming Equipment | | | | |
| 6.0 | Equipment | 2 | | |
| 6.1 | Joint Forming Equipment ³ | 2 | | |
| Pre-Pour Product Inspection | | | | |
| 7.0 | Reinforcing ¹ | 6 | | |
| 8.0 | Pre-Pour Inspection ¹ | 6 | | |
| 9.0 | Concrete Testing ^{1,5} | 6 | | |
| 9.9 | Compressive Strength Testing ¹ | 6 | | |
| Post-Pour Product Inspection | | | | |
| 10.0 | Curing | 4 | | |
| 11.1 | Repairs and Finishing | 2 | | |
| 11.2 | Product Visual Inspection | 2 | | |
| 11.3 | Product Dimensional Inspection ¹ | 6 | | |
| 11.4 | Gasketed Joints Dimensional inspection | 2 | | |
| 12.0 | Product Marking | 3 | | |
| Testing | | | | |
| 13.0 | Gasketed Product Testing ³ | 3 | | |
| Storage, Handling, Shipping and Final Inspection | | | | |
| 14.1 | Storage and Handling | 3 | | |
| 14.2 | Shipping Policy | 3 | | |
| 14.3 | Final Inspection | 3 | | |
| | Total Applicable Points | 81 | | |
| | Repeated deficiency score reduction ⁴ | | | |
| | Adjusted Score ² | | | |

Notes:¹Critical Element: Minimum Passing Score = 4.5²Minimum Passing Score = 80, Conditional Certification Score = 75³Criteria for gasketed box culverts.⁴Every repeated deficiency will have a reduction of 0.25% points from the final score.⁵Score for drycast concrete temperature testing is included in section 9.0

Note: If grade is marked "NA", possible points will not be added to the total score.

Audit Manual Score Summary Sheet Gasket Requirements

Plant _____

Date of Audit _____

Location _____

Inspector _____

| Section | Description | Possible Points (A) | Grade (B) | Score (A x B) |
|---|--|---------------------|-----------|---------------|
| Product Documentation | | | | |
| 1.0 | Quality Control Documents & Info. | 4 | | |
| 2.0 | Materials | 3 | | |
| 3.0 | Calibration | 3 | | |
| Design | | | | |
| 5.1 | Gasket Design Information | 3 | | |
| 5.4 | Gasket QC Test Procedures | 4 | | |
| Equipment | | | | |
| 6.0 | Equipment | 3 | | |
| Production Inspection | | | | |
| 8.1 | In-Process Production Testing ¹ | 6 | | |
| 8.2 | Production Control ¹ | 6 | | |
| 8.3 | QC/Production Inspection ¹ | 6 | | |
| Product Inspection | | | | |
| 11.0 | Repairs | 3 | | |
| 12.0 | Product Marking | 3 | | |
| Storage, Handling, Shipping and Final Inspection | | | | |
| 14.1 | Storage and Handling | 3 | | |
| 14.2 | Shipping Policy | 3 | | |
| 14.3 | Final Inspection | 3 | | |
| | Total Applicable Points | 53 | | |
| | Repeated Deficiency score reduction ³ | | | |
| | Adjusted Score ² | | | |

Notes:

1. Critical Element: Minimum Passing Score = 4.5
2. Minimum Passing Score = 80, Conditional Certification Score = 75
3. Every repeated deficiency will have a reduction of 0.25% points from the final score.

Note: If grade is marked "NA", possible points will not be added to the total score.

Grading Guideline

| Section | Title | General Comments | Common Deficiencies and Deductions |
|---------|------------------------------|---|--|
| 1.0 | Quality Control Documents | This section has several subsections that comprise the grading. Subsections are generally weighed equally for grading purposes. | All subsection not being completed deduct 100% of subsection weight |
| 2.0 | Materials: | This section has several materials to obtain certificates. | Deduct 5% for each missing monthly certificate over the past 12 months and deduct 10% for each missing quarterly or annual certificate. |
| 3.0 | Calibration: | This section includes equipment calibrations. | Deduct 20% for each missing calibration of batch plant, compression tester, or TEB test equipment. Deduct 10% for each missing calibration over the past 12 months for other equipment. Incomplete calibrations procedures deduct 5% per item. |
| 4.0 | Mix Designs | This section is related to concrete mix designs and w/c confirmations | Deduct 100% if plant does not have any current concrete mix designs. Deduct 20% if batch reports do not match concrete mix designs, except for allowable variations of materials. Deduct 10% for each material being batched out-of-required tolerance. Deduct 25% if W/C confirmations are not being completed or 5% per month based on % missing annually up to 25%. |
| 5.0 | Joints | This section includes subsections for joint drawings, calculations, gauge system and gasket testing. | Deduct 100% if no joint design drawings, calculations (SS) or spigot gaging system (SS). Deduct 10% if lacking tolerances for critical dimensions. Deduct 5 to 25% for improper gasket test methods. Deduct % for lack of gasket test records based on % of records missed. |
| 6.0 | Equipment | This section includes inspection of forms and joint forming equipment. | Deduct 10% for each instance of poor form conditions. Deduct 100% for lack of all joint forming inspection records. |
| 7.0 | Reinforcing | Design drawings for reinforcing must be on file as well as available to staff fabricating cages. | Deduct 100% if no reinforcing steel drawings are available. Deduct 10% if drawings are not available at cage fabrication area. Deduct 5% for each individual item missing from reinforcing drawing. Deduct 50% if all in-house drawn wire test reports are not available |
| 8.0 | Pre-pour Inspection | Subsections include reinforcing inspection, pre-pour visual, and pre-pour dimensional inspections. | Deduct 100% if all inspections are not performed and documented. Deduct 10% if tolerances are not checked. Deduct 5% plus % of inspections not performed correctly or missing documentation. |
| 9.0 | Concrete Testing | Subsections include various tests for plastic concrete and absorption. Subsections are weighted equally. | Deduct 100% of subsection weight if all testing is not performed. Deduct 10% for each incorrect test procedure. Deduct 5% plus % for missing documentation. |
| 9.9 | Compressive Strength Testing | Grading based on demonstration of test procedures and records. | Deduct 100% if all compressive strength testing is not performed. Deduct 10% for each incorrect test procedures. Deduct 5% based on each week of missing all documentation. |
| 10.0 | Curing | Curing policy, plant procedures and records. | Deduct 100% if no curing records or deduct 5% for each week of missing documentation. |

| | | | |
|---------------|---------------------------------------|---|--|
| 11.1 | Repair and Finishing | Review of policy and practice. | Deduct 100% if no policy. Deduct 10% if acceptable products not identified. Deduct up to 50% based on observations of poor quality in yarded products. |
| 11.2, 11.4 | Product Visual Inspection | This section includes demonstration of post-pour inspections and yarded product inspection. | Deduct 10% for each item not inspected by plant QC staff during demonstration of visual inspection procedures. Deduct 5% for each instance of poor quality observed in the yard. |
| 11.3 | Product Dimensional Inspection | This section includes demonstration of post-pour inspections and yarded product inspection. | Deduct 100% if all inspections are not performed or documented. Deduct 5% if a measurement or tolerance is not checked, for each measurement/tolerance to be checked. Deduct % of items that are not inspected and documented correctly based on observations and records. |
| 11.5 | Sanitary Joint Dimensional Inspection | Sanitary pipe requirement for joint testing. | Deduct 100% if none of the inspections are performed and documented. Deduct 20% if gauging system is not set up properly. Deduct % based on % of records incomplete. |
| 12.0 | Marking | Product markings need to match ASTM specifications and be durable. Inspect yarded products. | Deduct 100% if product marked with ACPA logo and product is not covered under certification Deduct 10% for each item noted in ASTM that is missing and 100% if product is mis-labeled by class or strength. Deduct 15% if markings are not durable. |
| 13.1 | Water Tightness Testing | Sanitary requirement - Proof-of design testing. Observe testing procedures and test documentation. | Deduct 100% if no records on file and no testing is performed. Deduct % of testing not complete. Deduct 50% for problems with test procedures. Deduct 10% if test observed failed. |
| 13.2 | Three Edge Bearing Test | Select pipe for testing and observe testing procedures. Review testing documentation and frequency. | Deduct 100% if no records on file and all testing not performed. Deduct 5% for each instance of pipe or size or class of testing records not meeting frequency requirements. Deduct 10% for each incorrect test procedure |
| 13.3 | Off Center Joint Test | Sanitary requirement - Proof-of design testing. Observe testing procedures and test documentation. | Deduct 100% if no records on file and no testing is performed. Deduct % of testing not complete. Deduct 50% for problems with test procedures. Deduct 10% if test observed failed. |
| 13.4 | Differential Shear Test | Sanitary requirement - Proof-of design testing. Observe testing procedures and test documentation. | Deduct 100% if no records on file and no testing is performed. Deduct % of testing not complete. Deduct 50% for major problems with test procedures. Deduct 10% if test observed failed. |
| 13.5 | Storm Joint Test | Gasketed storm pipe joint requirement - Proof-of design testing. Observe testing procedures and test documentation. | Deduct 100% if no records on file and no testing is performed. Deduct % of testing not complete. Deduct 50% for major problems with test procedures. Deduct 33% for not demonstrating test during audit. Deduct 10% if test observed failed. |
| 14.1 | Storage and Handling | Review plant policy and observe procedures. | Deduct 50% for no policy. Deduct 50% for poor storage and handling procedures. |
| 14.2 | Shipping Policy | Review plant policy and observe procedures. | Deduct 100% for no policy. Deduct 20% if policy does not define strength requirements. |
| 14.3 | Final Inspection | Review plant policy and observe procedures. | Deduct 50% for no policy. Deduct 100% if no final inspection is conducted Deduct up to 50% for poor inspection procedures or incomplete documentation, as required. |

| | | | |
|--|--|--|--|
| | | | Deduct 20% if staff not designated or trained. |
| | | | |

Note: if records are missing for more than 75% of required documentation, deduct 100%

APPENDIX C:

Suggested Practice for State Highway Agency Quality Review of Procedures of Precast Concrete Drainage Products Certified by the American Concrete Pipe Association

Suggested Practice for State Highway Agency Quality Review of Producers of Precast Concrete Drainage Products Certified by the American Concrete Pipe Association

1. SCOPE

This guideline provides recommended procedures that State Highway Agency (SHA) or their representative can follow when shadowing the American Concrete Pipe Association (ACPA) QCast Program plant audits. It is understood that each SHA may have special local requirements based on their unique situation and resources. This guide is intended to form a baseline review that can be applied nationally.

1.1 The ACPA certifies pipe and precast facilities through a quality program that requires the plants to conform to the industry standard ACPA QCast Plant Certification Manual. Plants are subject to annual third-party audits as part of this certification program.

1.2 The SHA is encouraged to contact the ACPA at info@concretepipe.org for any of the following:

1.2.1 Questions concerning the ACPA QCast quality process certification program.

1.2.2 The quality of products produced at an ACPA QCast certified plant is in question.

1.2.3 To shadow QCast plant audits to better understand the comprehensive nature of the ACPA QCast program. Once the request is initiated by the SHA, the third-party auditing firm will notify the SHA prior to subsequent plant audits until informed otherwise.

1.2.4 State specific requirements, in writing, that must be added to a facilities audit.

1.2.5 QCast reports of plants supplying product to the SHA. The ACPA holds confidentiality of these reports in high regard, but with permission of the plant, the ACPA will issue reports to the SHA on an annual basis.

1.2.6 To become a member of the QCast Users Group which discusses national improvements to the QCast program.

1.2.7 Questions for the ACPA Quality Advisory Group in regard to specific quality requirements and how they affect the quality of the product.

1.3 The purpose of the ACPA QCast certification is to establish that certified plant has the proper equipment, trained staff, and quality procedures in place to consistently produce quality products. The ACPA certification describes the product types that the plant is certified to produce under the QCast quality program.

1.4 The ACPA certification program covers all areas of quality control processes in its QCast-certified facilities, but it does not certify that any particular product meets a specific standard.

1.4.1 Unannounced plant audits by an independent audit agency are routinely performed annually. This audit intentionally varies over the year so that plant staff do not know when audits will occur. Therefore, it may be more or less than 12 months between ACPA audits; however, the plant is still certified.

1.4.1.1 In order to maintain certification for the subsequent year, a plant will re-apply and make payment by their quarterly anniversary date as shown in the bylaws of the QCast Manual. Upon receipt of the application and payment, the ACPA acknowledges the plants intent to continue in the program, and the plant is placed in the auditing queue and issued a certificate. The certificate is valid until the following anniversary date, unless the unannounced audit is not passed. If the audit is not passed, the plant is removed from the certification until they complete a successful audit.

1.4.1.2 Since all plant audits except initial audits are unannounced, the SHA should contact the ACPA to arrange the shadow audit with the third party auditor.

1.5 The ACPA QCast program manual, list of certified plants, and additional information is available from the ACPA website at www.concretepipe.org.

2. REFERENCED DOCUMENTS

2.1 American Concrete Pipe Association QCast Plant Certification Manual

2.2 AASHTO/ASTM Standards:

- AASHTO M170 / ASTM C76 (reinforced concrete pipe),
- AASHTO M206 / ASTM C506 (reinforced concrete arch pipe)
- AASHTO M207/ ASTM C507 (reinforced elliptical pipe)
- AASHTO M259 / ASTM C1577 (precast box culverts)
- ASTM C655 (circular pipe)
- ASTM C1504 (three-sided-structures)

- Other standards as applicable

3. AUDIT

The ACPA QCast program assesses the conformance of the manufacturing facility to the QCast Manual requirements. The following items are assessed by the third party auditor and are provided here as a guide for the SHA staff or their representative to follow during the shadow audit.

3.1 Quality Documentation, Specifications and Information

The auditors shall verify that specifications, documentation, and other information is current and satisfies the requirements for content and frequency.

3.2 Materials

The auditor shall verify that all material documentation on file is current and obtained at the required frequency.

3.3 Calibration

The auditor shall verify that production and testing equipment has been properly and accurately calibrated at the required frequencies. Written procedures for these calibrations shall also be reviewed. The auditor shall verify that the batching equipment has been calibrated through the maximum working range.

3.4 Mix Designs

The auditor shall review required documentation, including water/cement ratio confirmation, and verify that concrete being produced is the same proportion as mix designs on file. Plants shall not be required to submit mix designs for public record as many designs contain proprietary information.

3.5 Joints – Pipe and Manholes

3.5.1 Joint/Spigot Gauging Design Drawings and Calculations

The auditor shall review joint design drawings and calculations.

3.5.2 Gasket Quality Control – Sanitary Sewer Only

The plant shall demonstrate the equipment and procedures for measuring sanitary sewer pipe and manhole gaskets, except when they are measured by personnel from outside the plant. In the latter case, the procedure and inspection location shall be documented and filed with the Inspection Test Reports.

3.6 Joints - Precast, Box, and Three-Sided Structures: The auditor shall review joint design drawings.

3.7 Equipment – Pipe and Manholes

3.7.1 Forms

The auditor shall review plant procedures and required documentation. The auditor shall verify that the equipment is clean and in good operational condition.

3.7.2 Joint Forming Equipment

The auditor shall witness the equipment and procedures for measuring sanitary sewer pipe and manhole headers, pallets and truing rings (if used), except when they are measured by personnel from outside the plant. In the latter case, the procedure and inspection location shall be documented and filed with the Inspection Test Reports.

3.8 Equipment - Precast, Box, and Three-Sided Structures:

The auditor shall review plant procedures and required documentation. The auditor shall verify that the equipment is clean and in good operational condition.

3.9 Reinforcing Design

The auditor shall verify that detailed design information for all cages/ reinforcement being fabricated is available in the fabrication area.

3.10 Pre-Pour Inspection

3.10.1 Reinforcing Inspection

During the audit, inspection shall be performed on reinforcing produced on the day of the audit. The auditor shall witness reinforcing measuring techniques and verify that cages/reinforcement being produced meet design requirements.

3.10.2 Pre-Pour Visual Inspection

The auditor shall review the pre-pour visual inspection procedures and documentation.

3.10.3 Pre-Pour Dimensional Inspection

The auditor shall review the pre-pour dimensional inspection procedures and documentation.

3.11 Concrete Testing

The auditor shall review required documentation for content and frequency. Plant personnel shall demonstrate quality assurance/quality control competency during the audit by performing all applicable concrete tests.

3.11.1 In-house Tests

For tests that are in-house but run at a site other than the one being audited, a written procedure shall be on file with the appropriate test results. Tests that are performed by independent labs need not be accompanied by procedural documentation. In-house tests to be witnessed include:

- Slump or slump flow (wet cast concrete)
- Air content (wet cast concrete)
- Concrete temperature
- Concrete compression
- Concrete absorption
- Unit weight testing and calculation

3.12 Curing

The auditor shall review curing documentation and curing practices.

3.13 Post-Pour Inspection

3.13.1 Finishing and Repairs

The auditor shall review written repair and finishing procedures and inspect yarded product for the quality of repairs.

3.13.2 Finished Product Inspection

The auditor shall verify that the plant has functioning procedures in place for the visual inspecting of product. During the audit, the auditor shall inspect the appearance of product in the yard as well as those being prepared or loaded for shipment in order to ensure the product meets the appropriate specification.

3.13.3 Dimensional Test of Product

The auditor shall witness the technique for measuring product randomly selected by the auditor, and documentation of required ongoing inspections.

3.13.4 Joint Visual Inspection

3.13.4.1 Joint Dimension Measurement - Sanitary Pipe and Manholes Only

The auditor shall witness the plant's procedure and equipment for gauging pipe spigots by watching plant personnel gauge pipe or manhole spigots.

3.13.4.2 Box Culverts and Three-Sided Structures:

The auditor shall witness the assembly of three box culvert sections into one assembly, or 2 box culvert sections for boxes with spans greater than 10.' The assembly shall fit so that the maximum joint opening at any one point is 1".

3.14 Product Marking

The auditor shall inspect yarded product for required marking.

3.15 Product Testing - Pipe and Manhole Only

This Manual includes an audit of inspection and tests performed by the plant on finished product. Since the set-up of finished product tests requires considerable time and effort, the auditor shall randomly select pipe to be tested on the onset of the audit. This shall allow adequate time for plant personnel to set up for afternoon testing.

3.15.1 Water Tightness of Pipe – Sanitary Sewer Only

For each test procedure, the auditor shall witness the plant's procedure, equipment and reporting for measuring the water tightness of product selected for test by the inspector.

The plant shall also demonstrate through documentation, that pressure change measuring equipment and testing time meet the minimum requirements of this Manual.

3.15.2 Three-Edge-Bearing Testing of Pipe

The auditor shall witness the plant's procedures, equipment and reporting for measuring the three-edge-bearing strength up to a 0.01-in. crack width of one pipe selected for test by the auditor. Prior to performing the test, the auditor shall witness dimensional measurements of the pipe section being tested.

3.15.3 Off-Center Joint Test - Sanitary Sewer Only

The auditor shall witness the plant's procedure, equipment and reporting for the offcenter joint test of a single set-up consisting of two pipe selected by the auditor. The test medium may be hydrostatic or vacuum.

3.15.4 Differential Joint Shear Test - Sanitary Sewer Only

The auditor shall witness the plant's procedure, equipment and reporting for the differential joint shear test of a single set-up consisting of two pipe selected by the auditor.

3.15.5 Storm Sewer and Culvert Joint Test - Storm and Culvert

The auditor shall witness the plant's procedure, equipment and reporting for the storm sewer and culvert joint test of a single set-up consisting of two gasketed pipe selected by the auditor.

3.16 Storage, Handling, Shipping and Final Inspection

3.16.1 Handling and Storage

The auditor shall inspect product handling operations, to ensure that they meet the requirements of this Manual.

3.16.2 Shipping Policy

The auditor shall review the plants shipping policy and verify that product being shipped meets the requirements of that policy.

3.17 Final Inspection

The auditor shall verify that the plant has a policy and functioning procedure in place for final inspection of product.

4. CLOSURE

Most questions related to the ACPA QCast requirements should be able to be answered by the plant's QC Coordinator. However, ACPA staff are available to answer questions and address any concerns related to QCast certified plants.